

Hydraulic power packs type HKL and HKLW

For 1~ and 3~phase mains

Fan cooled, for continuous and intermittent service; single and dual circuit pumps



Compact hydraulic power packs for vertical installation:

HK 2	D 7600-2
HK 3	D 7600-3
HK 4 and HKF 4	D 7600-4
KA 2	D 8010
KA 4	D 8010-4
MPN	D 7207

Flow Q_{max}	= approx. 22 lpm (1450 rpm)
Pressure p_{max}	= 700 bar (Radial piston pump) = 200 bar (Gear pump)

1. General

1.1 Basic layout

Terminal box with cable gland M20x1.5. Additional terminal strip for optional float and/or temperature switch. There is also a version with central plug (Co. HARTING).

Main connection pedestal with one (single circuit pump) or two pressure outlets (dual circuit pump) and return port. Prepared (interface) for the mounting of connection blocks for ongoing pressure and return pipes or with directly mounted directional valve banks (acc. to D 6905 ++).

Filler neck with breather screen filter 0.4 x 0.22

Filling gauge with Max./Min.- marking

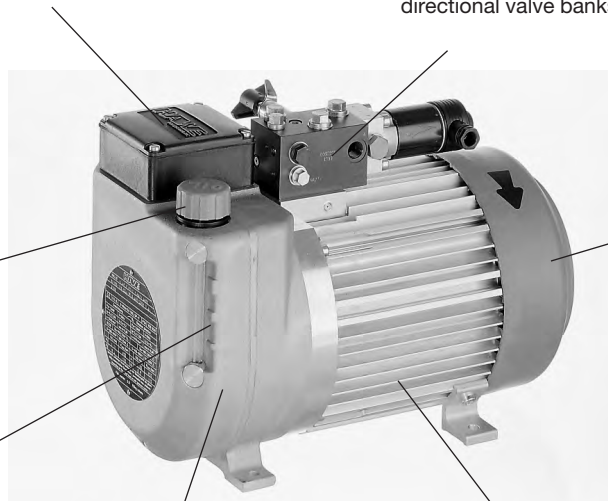

Bottom housing section with radial piston pump for pressure ranges up to 700 bar or gear pump for pressure ranges up to 200 bar.

Finned tubular tank with shrunk-in stator. This helps to conduct the generated heat from the winding to the cooling fins.

Fan shroud with largely dimensioned fan wheel. The fan shroud directs the stream of air, which is created by the fan wheel, through the ribs and thereby ensures an intensive heat dissipation to the surroundings. These compact hydraulic power packs are therefore suitable for operating modes S1 (continuous operation) in the range of the nominal power as well as S6 (permanent running with idle sequences) conf. VDE 0530. Thereby approx. up to 1.8 of the nom. power rating can be employed. S3 (intermittent service) is also possible. The cooling effect of the large finned surface is also very good at standstill of the motor.

Table of contents

1. General	1	4. Unit dimensions	16
1.1 Basic layout	1	4.1 Mounting, hole pattern	16
1.2 Type coding	2	4.2 Basic pump	16
2. Available versions	3	4.3 Electrical and hydraulic connection	18
2.1 Motor and tank section	3	5. Appendix	20
2.2 Pump section	4	5.1 Notes regarding selection	20
2.2.1 Single circuit pumps	4	5.2 Assembly and installation notes	24
2.2.2 Dual circuit pump with joint connection pedestal.....	6	5.3 Servicing	26
2.2.3 Dual circuit pumps with separate connection pedestal.....	11		
3. Further characteristic data	13		
3.1 General	13		
3.2 Hydraulic	13		
3.3 Electrical data	14		



HAWE HYDRAULIK SE
STREITFELDSTR. 25 • 81673 MÜNCHEN

D 7600-3L
Hydraulic power pack
Type HKL 3

1.2 Type coding

Order example:

(Single circuit pump, see section 2.2.1)

HKL 34 DT/1P - H 7,7 - A1/150 - 3x400/230V 50Hz

(Dual circuit pump, see section 2.2.2 and section 2.2.3)

HKLW 328T /1C - HZ 0,88/5,2 - NA31-A700R/100/120-WGZ4-1R-WG110 - 1x110V 60Hz - G 1/4 x 300

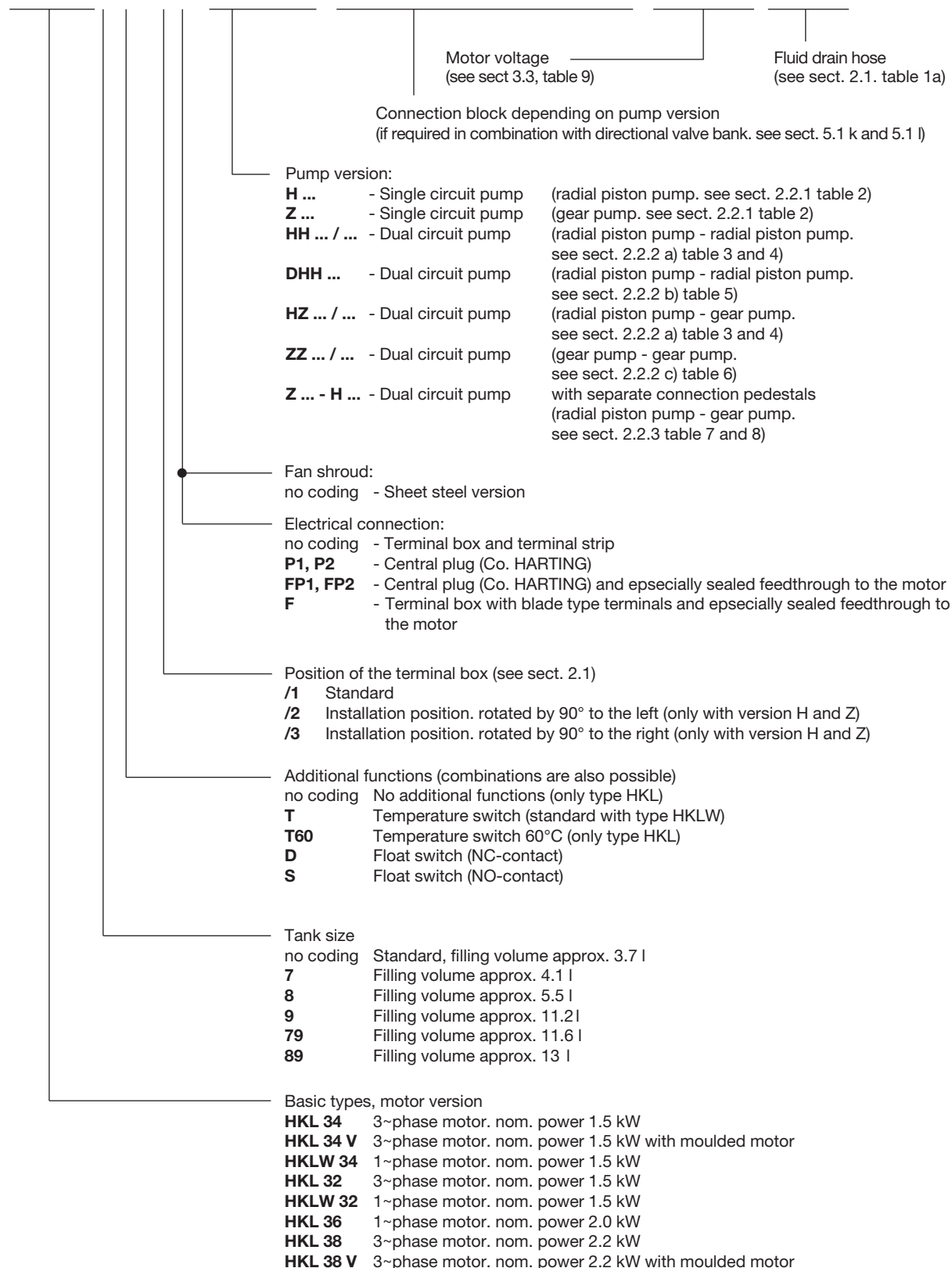

2. Available versions

2.1 Motor and tank section

Motor and tank section plus the pump section (see section 2.2) yield the basic hydraulic power pack.

Order	HKL 348 DT /1P1 - H 1,15	- A1/500	-3x400/230V 50Hz
example:	HKL 32 /2 - H 6,70	- B31/80 - EM11V - G 24	-3x400V 50Hz
	HKLW 34 DT /1 - Z 6,0	- AL11C/80	-1x230V 50Hz
	HKLW 32 T /1 - HZ 0,88/5,2	- NA31-A700R/100/120-WGZ4-1R-WG110	-1x110V 60Hz - G 1/4 x 300
		Pump version (sect. 2.2)	Motor voltage (sect. 3.3 table 9) Fluid drain hose (sect. 2.1. table 1a)

Table 1: Basic type and power rating

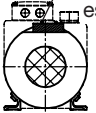
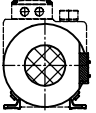
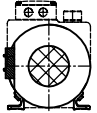
Basic type	Coding	For available motor voltage 50 Hz/60 Hz and additional data. see sect. 3.3 table 9		
		3~phase motor	Power (kW)	Speed (min ⁻¹)
Basic type	HKL 34 HKL 34 V ^{1) 3)}	3~phase motor	1.5 / 1.8	1410 (50 Hz) / 1690 (60 Hz)
	HKL 32		1.5 / 1.8	2840 (50 Hz) / 3410 (60 Hz)
	HKL 38 ¹⁾ HKL 38 V ^{1) 3)}	2.2 / 2.65	1375 (50 Hz) / 1650 (60 Hz)	
Basic type	HKLW 34 ¹⁾	1~phase motor	1.5 / 1.5	1375 (50 Hz) / 1650 (60 Hz)
	HKLW 32		1.5 / 1.5	2800 (50 Hz) / 3420 (60 Hz)
	HKLW 36 ⁵⁾	2.0	3420 (60 Hz)	
Note: A actual power consumption is load dependent and can be up to 1.8 x nominal power.				
Tank size	no coding	Filling volume (l)	Usable filling volume (l)	
	7 ⁴⁾	3.7	1.7	
	8	4.1	2.1 / 1.7 ²⁾	
	9	5.5	2.6 / 1.7 ²⁾	
	79 ⁴⁾	11.2	8.2	
	89	11.6	8.6 / 8.2 ²⁾	
Additional functions	no coding	only type HKL		
	D	Float switch (NC-contact)		
	S	Float switch (NO-contact)		
	T	Temperature switch (standard with type HKLW)		
	T 60	Temperature switch (switchpoint 60°C only with type HKL)		
Arrangement of the connection pedestal (viewed from the fan wheel) for direct mounting of connection block / directional valve bank (see sect. 5.1 k and 5.1 l)	1	standard Conne- ction ped- estal	2	only at single circuit pumps acc. to sect. 2.2.1 90°turned
				
			3	90°turned
				
Electrical connection	no coding	Terminal box		
	P1 P2	Central plug HAN 10 E (Co. HARTING) (for difference, see sect. pos. 4.2)		
	F FP1 FP2	Oil proof vers., terminal box with blade type contacts (F) or central plug (FP1 , FP2) (see note in sect. 5.1 e)		
Fan shroud	no coding	Sheet steel version		

Symbol accordingly to the 1. order example

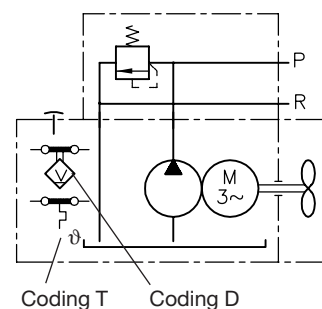

- 1) Only in comb. with tank size **7, 8, 79** or **89**
- 2) Usable filling volume for single/dual circuit pumps
- 3) Version with moulded stator, see note in sect. 5.1 e
- 4) Only in comb. with pump vers. **HZ...**, **Z...**-H...
- 5) only in combination with pump version **HZ...** and tank size coding **7** or **79**

Table 1 a:

* (BSPP)

Coding	Description
no coding	Tapped plug G 1/4*
G 1/4* x 300	Fluid drain hose approx. 300 mm with ball cock
G 1/4* x 500	Fluid drain hose approx. 500 mm with ball cock
G 1/4* W x 300	Fluid drain hose approx. 300 mm with elbow and ball cock
G 1/4* W x 500	Fluid drain hose approx. 500 mm with elbow and ball cock

2.2 Pump section
2.2.1 Single circuit pumps

Order example 1: HKL 348 DT/1 - **H6,7** - A1/180 3x400V 50Hz
 Order example 2: HKL 32/1P1 - **Z4,5** - AL11E/120 3x400/230V 50Hz

Table 2 a: Single circuit pumps with 3~phase motor
 Radial piston pump **H** or gear pump **Z**

Note: Guide line figure, based on nom. rev. rating at mains frequency 50 Hz or 60 Hz.

The delive flow rating Q_{pu} is a guide line figure, based on nom. rev. rating that will be slightly reduced dep. on load (see sect. 3.3).

For notes regarding pressure p_{max} and p_1 (see sect. 3.3, table 9). The perm. pressure p_{max} correspond to motors 3x400 / 230V 60 Hz. For other voltage: $p_{max} = (pV_g)_{max} / V_g$ with $(pV_g)_{max}$ from table 9 on page 14. The max. value for the hydraulic work $(pV_g)_{max}$ is reduced by 10% with pumps type **Z**.

* **Note:** Gear pumps size 2 can be combined only with tank coding **9** and **89** (see table 1)!

Circuitry symbol acc. to order example 1:

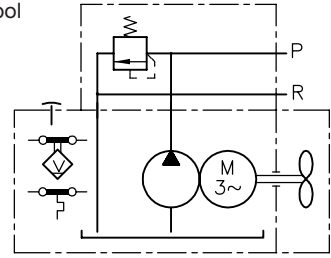

H	Coding for radial piston pump			Piston diameter (mm)									
				6	7	8	10	12	13	14	15	16	
	Delivery flow coding (4-cylinder pump)			1,15	1,65	2,15	3,35	4,8	5,7	6,7	7,7	8,7	
	Geom. displace V_g (cm ³ /rev)			0.86	1.17	1.53	2.39	3.44	4.04	4.68	5.37	6.11	
HKL 34	Delivery Q_{pu} (lpm)	50 Hz		1.21	1.65	2.15	3.37	4.85	5.69	6.60	7.57	8.62	
		60 Hz		1.45	1.98	2.58	4.04	5.81	6.82	7.91	9.08	10.33	
	Perm. pressure p_{max} (bar)			700	700	700	485	335	285	245	215	190	
	Dauerbetrieb S1 p_1 (bar)			670	490	380	240	170	140	120	105	95	
HKL 32	Delivery Q_{pu} (lpm)	50 Hz		2.44	3.32	4.34	6.78	9.76	11.46	13.29	15.26	17.36	
		60 Hz		2.93	3.99	5.21	8.14	11.72	13.76	15.96	18.32	20.84	
	Perm. pressure p_{max} (bar)			700	520	395	255	175	150	130	110	95	
	Continuous operation S1 p_1 (bar)			330	245	185	120	80	70	60	50	45	
HKL 38	Delivery Q_{pu} (lpm)	50 Hz		1.18	1.61	2.10	3.28	4.73	5.55	6.43	7.39	8.40	
		60 Hz		1.42	1.93	2.52	3.94	5.67	6.66	7.72	8.86	10.09	
	Perm. pressure p_{max} (bar)			700	700	700	560	390	330	290	250	220	
	Continuous operation S1 p_1 (bar)			700	700	570	360	250	210	180	160	140	
Z	Coding for gear			Size 1									
	Delivery flow coding			1,1	1,7	2	2,7	3,5	4,5	5,2	6,4	6,9	
	Geom. displace V_g (cm ³ /rev)			0.80	1.20	1.60	2.10	2.50	3.30	3.60	4.30	4.80	
	HKL 34	Delivery Q_{pu} (lpm)	50 Hz		1.13	1.69	2.26	2.96	3.53	4.65	5.08	6.06	6.77
			60 Hz		1.35	2.03	2.70	3.55	4.23	5.58	6.08	7.27	8.11
		Perm. pressure p_{max} (bar)			210	210	210	210	210	210	195	185	170
		Continuous operation S1 p_1 (bar)			210	210	210	210	210	160	145	120	105
	HKL 32	Delivery Q_{pu} (lpm)	50 Hz		2.27	3.41	4.54	5.96	7.10	9.37	10.22	12.21	13.63
			60 Hz		2.73	4.09	5.46	7.16	8.53	11.25	12.28	14.66	16.37
		Perm. pressure p_{max} (bar)			210	210	210	210	210	150	130	110	95
		Continuous operation S1 p_1 (bar)			210	210	185	120	80	70	60	50	45
	HKL 38	Delivery Q_{pu} (lpm)	50 Hz		1.10	1.65	2.20	2.89	3.44	4.54	4.95	5.91	6.60
			60 Hz		1.32	1.98	2.64	3.47	4.13	5.45	5.94	7.10	7.92
		Perm. pressure p_{max} (bar)			210	210	210	210	210	210	195	185	170
		Continuous operation S1 p_1 (bar)			210	210	210	210	210	210	180	160	140
	Z	Coding for gear			Size 1				Size 2 *				
Delivery flow coding			8,2	8,8	11,3	9,0	11	12,3	16	21			
Geom. displace V_g (cm ³ /rev)			5.80	6.20	7.9	6.00	7.60	8.50	11.00	14.50			
HKL 34		Delivery Q_{pu} (lpm)	50 Hz		8.18	8.74	11.14	8.46	10.72	11.99	15.51	20.45	
			60 Hz		9.80	10.48	13.35	10.14	12.84	14.37	18.59	24.51	
		Perm. pressure p_{max} (bar)			135	125	115	170	140	125	95	75	
		Continuous operation S1 p_1 (bar)			90	80	60	85	65	60	45	35	
HKL 32		Delivery Q_{pu} (lpm)	50 Hz		16.47	17.61	22.44	17.04	21.58	24.14	31.24	41.18	
			60 Hz		19.78	21.14	26.94	20.46	25.92	28.99	37.51	49.45	
		Perm. pressure p_{max} (bar)			95	90	65	95	75	65	50	35	
		Continuous operation S1 p_1 (bar)			45	40		40	30	30			
HKL 38		Delivery Q_{pu} (lpm)	50 Hz		7.98	8.53	10.86	8.25	10.45	11.69	15.13	19.94	
			60 Hz		9.57	10.23	13.04	9.90	12.54	14.03	18.15	23.93	
		Perm. pressure p_{max} (bar)			135	125	115	195	180	160	125	95	
		Continuous operation S1 p_1 (bar)			135	125	95	130	100	90	70	50	

Table 2 b: Single circuit pumps with 1~phase motor
Radial piston pump **H** or gear pump **Z**

Note: Guide line figure, based on nom. rev. rating at mains frequency 50 Hz or 60 Hz. The delivery flow rating Q_{pu} is a guide line figure, based on nom. rev. rating that will be slightly reduced dep. on load (see sect. 3.3). For notes regarding pressure p_{max} and p_1 (see sect. 3.3, table 9).

The perm. pressure p_{max} correspond to motors 1x230V 50 Hz / 1x110V 60 Hz.

For other voltage: $p_{max} = (pV_g)_{max} / V_g$ with $(pV_g)_{max}$ from table 9 on page 14. The max. value for the hydraulic work $(pV_g)_{max}$ is reduced by 10% with pumps type **Z**.

A capacitor is mandatory for the version with 1~phase motor, which is not scope of delivery. For recommendations and notes regarding selection, see sect. 3.3 and. 5.1 i.

These power packs won't start-up against pressure!

* **Note:** Gear pumps size 2 can be combined only with tank coding **9** and **89** (see table 1)!

H	Coding for radial piston pump		Piston diameter (mm)								
			6	7	8	10	12	13	14	15	16
	Delivery flow coding		1,15	1,65	2,15	3,35	4,8	5,7	6,7	7,7	8,7
	Geom. displace V_g (cm ³ /rev)		0.86	1.17	1.53	2.39	3.44	4.04	4.68	5.37	6.11
HKLW 34	Delivery Q_{pu} (lpm)	50 Hz	1.18	1.61	2.10	3.28	4.73	5.55	6.43	7.39	8.40
		60 Hz	1.42	1.93	2.52	3.94	5.67	6.66	7.72	8.86	10.09
	Perm. pressure p_{max} (bar)	50 Hz	700	700	540	340	240	205	175	150	135
		60 Hz	690	510	390	250	170	145	125	110	95
	Continuous oper. S1 p_1 (bar)	50 Hz	690	510	390	250	170	145	125	110	95
		60 Hz	560	410	315	200	140	120	100	90	75
HKLW 32	Delivery Q_{pu} (lpm)	50 Hz	2.41	3.28	4.28	6.69	9.63	11.30	13.10	15.04	17.11
		60 Hz	2.94	4.00	5.23	8.17	11.76	13.80	16.00	18.37	20.90
	Perm. pressure p_{max} (bar)	50 Hz	420	310	235	150	105	85	75	65	55
		60 Hz	285	210	160	100	70	60	50	45	35
	Continuous oper. S1 p_1 (bar)	50 Hz	340	250	190	120	85	70	60	50	45
		60 Hz	250	185	140	90	60	50	45	40	35
Z	Coding for gear		Size 1								
	Delivery flow coding		1,1	1,7	2	2,7	3,5	4,5	5,2	6,4	6,9
	Geom. displace V_g (cm ³ /rev)		0.80	1.20	1.60	2.10	2.50	3.30	3.60	4.30	4.80
HKLW 34	Delivery Q_{pu} (lpm)	50 Hz	1.10	1.65	2.20	2.89	3.44	4.54	4.95	5.91	6.60
		60 Hz	1.32	1.98	2.64	3.47	4.13	5.45	5.94	7.10	7.92
	Perm. pressure p_{max} (bar)	50 Hz	210	210	210	210	210	210	195	170	135
		60 Hz	210	210	210	210	210	160	150	125	110
	Continuous oper. S1 p_1 (bar)	50 Hz	210	210	210	210	210	170	155	130	115
		60 Hz	210	210	210	205	175	130	120	102	90
HKLW 32	Delivery Q_{pu} (lpm)	50 Hz	2.24	3.36	4.48	5.88	7.00	9.24	10.08	12.04	13.44
		60 Hz	2.74	4.10	5.47	7.18	8.55	11.29	12.31	14.71	16.42
	Perm. pressure p_{max} (bar)	50 Hz	210	210	210	160	135	100	95	75	70
		60 Hz	210	195	140	105	90	65	60	50	45
	Continuous oper. S1 p_1 (bar)	50 Hz	210	210	160	120	100	75	70	60	50
		60 Hz	210	160	120	90	75	55	50	40	35
Z	Coding for gear		Size 1			Size 2 *					
	Delivery flow coding		8,2	8,8	11,3	9,0	11	12,3	16	21	
	Geom. displace V_g (cm ³ /rev)		5.80	6.20	7.90	6.00	7.60	8.50	11.00	14.50	
HKLW 34	Delivery Q_{pu} (lpm)	50 Hz	7.98	8.53	10.86	8.25	10.45	11.69	15.13	19.24	
		60 Hz	9.57	10.23	13.04	9.90	12.54	14.03	18.15	23.93	
	Perm. pressure p_{max} (bar)	50 Hz	135	120	105	130	100	90	70	50	
		60 Hz	95	85	75	95	75	65	50	35	
	Continuous oper. S1 p_1 (bar)	50 Hz	90	85	70	90	70	60	45	35	
		60 Hz	75	70	55	70	55	50	40	30	
HKLW 32	Delivery Q_{pu} (lpm)	50 Hz	16.24	17.36	22.12	16.80	21.28	23.80	30.80	40.60	
		60 Hz	19.84	21.20	27.02	20.52	25.99	29.07	37.62	49.59	
	Perm. pressure p_{max} (bar)	50 Hz	55	50	45	55	45	40	30		
		60 Hz	45	35	30	35	30				
	Continuous oper. S1 p_1 (bar)	50 Hz	40	40	30	40	30	30			
		60 Hz	30			30					

2.2.2 Dual circuit pump with joint connection pedestal

a) Version radial piston pump -- radial piston pump and radial piston pump -- gear pump coding HH

For version HKL ... DHH and HKL ... ZZ, see table 5 and 6

Order example 1: HKLW 32 DT/1 - **HH 0,88/5,7** - NA31-A700R/100/120-WGZ4-1R-WG110 1x110V 60Hz

Order example 2: HKL 348 /1 - **HZ 0,57/4,5** - C30 - A1/300 3x400/230V 50Hz

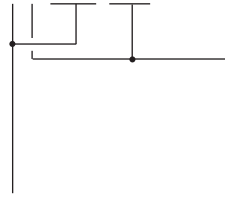

Pressure connection P3:
Radial piston pump **H**
or gear pump **Z**
acc. to table 4

Circuitry symbol acc. to order example 2:

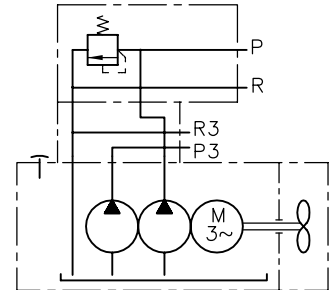

Table 3 a: Pressure connection P1
Dual circuit pumps with 3~phase motor
Radial piston pump **H**

Note:

Guide line figure, based on nom. rev. rating at mains frequency 50 Hz or 60 Hz.
The delivery flow rating Q_{pu} is a guide line figure, based on nom. rev. rating that will be slightly reduced dep. on load (see sect. 3.3).
For notes regarding pressure p_{max} and p_1 (see sect. 3.3, table 9).
The perm. pressure p_{max} correspond to motors 3x400 / 230V 60 Hz.
For other voltage: $p_{max} = (pV_{g,max}/V_g)$ with $(pV_{g,max})$ from table 9 on page 14. The max. value for the hydraulic work $(pV_g)_{max}$ is reduced by 10% with pumps type **HH, HZ, ZZ, DHH** or **Z-H**.

H	Coding for radial piston pump		Piston diameter (mm)						
			4	4/5	5	6	7	8	9
	Delivery flow coding (4-cylinder pump)		0,37	0,47	0,57	0,88	1,12	1,42	1,82
	Geom. displace V_g (cm ³ /rev)		0.25	0.32	0.39	0.57	0.77	1.01	1.27
HKL 34	Delivery Q_{pu} (lpm)	50 Hz	0.35	0.45	0.55	0.80	1.09	1.42	1.79
		60 Hz	0.42	0.54	0.66	0.96	1.30	1.70	2.15
	Perm. pressure p_{max} (bar)		700	700	700	700	700	700	550
HKL 32	Delivery Q_{pu} (lpm)	50 Hz	0.71	0.90	1.12	1.61	2.19	2.86	3.61
		60 Hz	0.86	1.08	1.34	1.93	2.62	3.43	4.34
	Perm. pressure p_{max} (bar)		700	700	700	700	700	570	450
HKL 38	Förderstrom Q_{pu} (lpm)	50 Hz	0.35	0.44	0.54	0.78	1.06	1.38	1.75
		60 Hz	0.41	0.52	0.65	0.93	1.27	1.66	2.10
	Perm. pressure p_{max} (bar)		700	700	700	700	700	700	700

Table 3 b: Pressure connection P1
Dual circuit pumps with 1~phase motor
Radial piston pump **H**

Note:

Guide line figure, based on nom. rev. rating at mains frequency 50 Hz or 60 Hz.
The delivery flow rating Q_{pu} is a guide line figure, based on nom. rev. rating that will be slightly reduced dep. on load (see sect. 3.3).
For notes regarding pressure p_{max} and p_1 (see sect. 3.3, table 9).
The perm. pressure p_{max} correspond to motors 1x230V 50 Hz / 1x110V 60 Hz.
For other voltage: $p_{max} = (pV_{g,max}/V_g)$ with $(pV_{g,max})$ from table 9 on page 14.
A capacitor is mandatory for the version with 1-phase motor, which is not scope of delivery. For recommendations and notes regarding selection, see sect. 3.3 and. 5.1 i. These power packs won't start-up against pressure!

H	Coding for radial piston pump		Piston diameter (mm)						
			4	4/5	5	6	7	8	9
	Delivery flow coding		0,37	0,47	0,57	0,88	1,12	1,42	1,82
	Geom. displace V_g (cm ³ /rev)		0.25	0.32	0.39	0.57	0.77	1.01	1.27
HKLW 34	Delivery Q_{pu} (lpm)	50 Hz	0.35	0.44	0.54	0.78	1.06	1.38	1.75
		60 Hz	0.41	0.52	0.65	0.93	1.27	1.66	2.10
	Perm. pressure p_{max} (bar)	50 Hz	700	700	700	700	700	700	610
		60 Hz	700	700	700	700	700	560	440
HKLW 32	Delivery Q_{pu} (lpm)	50 Hz	0.70	0.89	1.10	1.58	2.16	2.81	3.56
		60 Hz	0.86	1.09	1.34	1.93	2.63	3.44	4.35
	Perm. pressure p_{max} (bar)	50 Hz	700	700	700	600	440	335	265
		60 Hz	700	700	590	410	300	230	180
HKLW 36	Delivery Q_{pu} (lpm)	60 Hz	0.86	1.09	1.34	1.93	2.63	3.44	4.35
		Perm. pressure p_{max} (bar)	60 Hz	700	700	700	515	380	290

Continuation sect. 2.2.2 a

Order example 1: HKLW 32 DT/1 - **HH 0,88/5,7** - NA31- A700R/100/120-WGZ4-1R-WG110 1x110V 60Hz
 Order example 2: HKL 348 /1 - **HZ 0,57/4,5** - C30 - A1/300 3x400/230V 50Hz

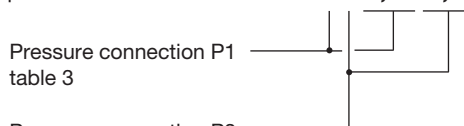

Table 4 a: Pressure connection P3
 Dual circuit pumps with 3~phase motor
 Radial piston pump **H** or gear pump **Z**

Note:

Guide line figure, based on nom. rev. rating at mains frequency 50 Hz or 60 Hz.

The delivery flow rating Q_{pu} is a guide line figure, based on nom. rev. rating that will be slightly reduced dep. on load (see sect. 3.3).

For notes regarding pressure p_{max} and p_1 (see sect. 3.3, table 9).

The perm. pressure p_{max} correspond to motors 3x400 / 230V 60 Hz.

For other voltage: $p_{max} = (pV_g)_{max}/V_g$ with $(pV_g)_{max}$ from table 9 on page 14. The max. value for the hydraulic work $(pV_g)_{max}$ is reduced by 10% with pumps type **HH, HZ, ZZ, DHH** or **Z-H**.

H	Coding for radial piston pump		Piston diameter (mm)								
			6	7	8	10	12	13	14	15	16
	Delivery flow coding (4-cylinder pump)		1,15	1,65	2,15	3,35	4,8	5,7	6,7	7,7	8,7
	Geom. displace V_g (cm ³ /rev)		0.86	1.17	1.53	2.39	3.44	4.04	4.68	5.37	6.11
HKL 34	Delivery Q_{pu} (lpm)	50 Hz	1.21	1.65	2.15	3.37	4.85	5.69	6.60	7.57	8.62
		60 Hz	1.45	1.98	2.58	4.04	5.81	6.82	7.91	9.08	10.33
	Perm. pressure p_{max} (bar)			700	700	700	460	315	270	235	200
HKL 32	Delivery Q_{pu} (lpm)	50 Hz	2.44	3.32	4.34	6.78	9.76	11.46	13.29	15.26	17.36
		60 Hz	2.93	3.99	5.21	8.14	11.72	13.76	15.96	18.32	20.84
	Perm. pressure p_{max} (bar)			670	490	375	240	165	140	120	105
HKL 38	Delivery Q_{pu} (lpm)	50 Hz	1.18	1.61	2.10	3.28	4.73	5.55	6.43	7.39	8.40
		60 Hz	1.42	1.93	2.52	3.94	5.67	6.66	7.72	8.86	10.09
	Perm. pressure p_{max} (bar)			700	700	700	560	390	330	290	250

Z	Coding for gear		Size 1								
			1,1	1,7	2	2,7	3,5	4,5	5,2	6,4	6,9
	Delivery flow coding		1,1	1,7	2	2,7	3,5	4,5	5,2	6,4	6,9
	Geom. displace V_g (cm ³ /rev)		0.80	1.20	1.60	2.10	2.50	3.30	3.60	4.30	4.80
HKL 34	Delivery Q_{pu} (lpm)	50 Hz	1.13	1.69	2.26	2.96	3.53	4.65	5.08	6.06	6.77
		60 Hz	1.35	2.03	2.70	3.55	4.23	5.58	6.08	7.27	8.11
	Perm. pressure p_{max} (bar)			210	210	210	210	210	210	195	170
HKL 32	Delivery Q_{pu} (lpm)	50 Hz	2.27	3.41	4.54	5.96	7.10	9.37	10.22	12.21	13.63
		60 Hz	2.73	4.09	5.46	7.16	8.53	11.25	12.28	14.66	16.37
	Perm. pressure p_{max} (bar)			210	210	210	210	210	175	160	130
HKL 38	Delivery Q_{pu} (lpm)	50 Hz	1.10	1.65	2.20	2.89	3.44	4.54	4.95	5.91	6.60
		60 Hz	1.32	1.98	2.64	3.47	4.13	5.45	5.94	7.10	7.92
	Perm. pressure p_{max} (bar)			210	210	210	210	210	210	195	185

Z	Coding for gear		Size 1		
			8,2	8,8	11,3
	Delivery flow coding		8,2	8,8	11,3
	Geom. displace V_g (cm ³ /rev)		5.80	6.20	7.9
HKL 34	Delivery Q_{pu} (lpm)	50 Hz	8.18	8.74	11.14
		60 Hz	9.80	10.48	13.35
	Perm. pressure p_{max} (bar)			130	125
HKL 32	Delivery Q_{pu} (lpm)	50 Hz	16.47	17.61	22.44
		60 Hz	19.78	21.14	26.94
	Perm. pressure p_{max} (bar)			95	90
HKL 38	Delivery Q_{pu} (lpm)	50 Hz	7.98	8.53	10.86
		60 Hz	9.57	10.23	13.04
	Perm. pressure p_{max} (bar)			150	135

Continuation sect. 2.2.2 a

Order example 1: HKLW 32 DT/1 - **HH 0,88/5,7** - NA31 - A700R/100/120-WGZ4-1R-WG110 1x110V 60Hz
 Order example 2: HKL 348 /1 - **HZ 0,57/4,5** - C30 - A1/300 3x400/230V 50Hz

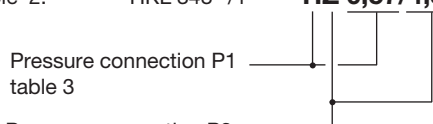

Table 4 b: Pressure connection P3
 Dual circuit pumps with 1~phase motor
 Radial piston pump **H** oder gear pump **Z**

Note:

Guide line figure, based on nom. rev. rating at mains frequency 50 Hz or 60 Hz.

The delivery flow rating Q_{pu} is a guide line figure, based on nom. rev. rating that will be slightly reduced dep. on load (see sect. 3.3).

For notes regarding pressure p_{max} and p_1 (see sect. 3.3, table 9).

The perm. pressure p_{max} correspond to motors 1x230V 50

Hz / 1x110V 60 Hz.

For other voltage: $p_{max} = (pV_g)_{max} / V_g$ with $(pV_g)_{max}$ from table 9 on page 14. The max. value for the hydraulic work $(pV_g)_{max}$ is reduced by 10% with pumps type **HH, HZ, ZZ, DHH** or **Z-H**.

A capacitor is mandatory for the version with 1~phase motor, which is not scope of delivery. For recommendations and notes regarding selection, see sect. 3.3 and. 5.1 i. These power packs won't start-up against pressure!

Circuitry symbol acc. to order example 1:

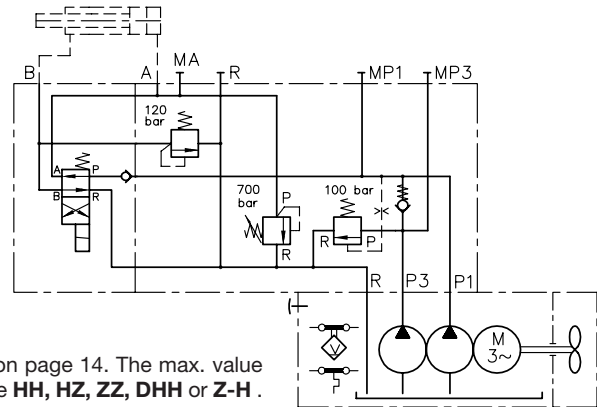

H	Coding for radial piston pump	6	7	8	10	12	13	14	15	16	
	Delivery flow coding	1,15	1,65	2,15	3,35	4,8	5,7	6,7	7,7	8,7	
	Geom. displace V_g (cm ³ /rev)	0.86	1.17	1.53	2.39	3.44	4.04	4.68	5.37	6.11	
HKLW 34	Delivery Q_{pu} (lpm)	50 Hz	1.18	1.61	2.10	3.28	4.73	5.55	6.43	7.39	8.40
		60 Hz	1.42	1.93	2.52	3.94	5.67	6.66	7.72	8.86	10.09
	Perm. pressure p_{max} (bar)	50 Hz	700	665	510	325	225	195	165	145	125
		60 Hz	660	480	370	235	165	140	120	100	90
HKLW 32	Delivery Q_{pu} (lpm)	50 Hz	2.41	3.28	4.28	6.69	9.63	11.30	13.10	15.04	17.11
		60 Hz	2.94	4.00	5.23	8.17	11.76	13.80	16.00	18.37	20.90
	Perm. pressure p_{max} (bar)	50 Hz	390	290	220	140	95	80	70	60	50
		60 Hz	272	200	150	95	65	55	50	40	35
Z	Coding for gear										
	Delivery flow coding	1,1	1,7	2	2,7	3,5	4,5	5,2	6,4	6,9	
	Geom. displace V_g (cm ³ /rev)	0.80	1.20	1.60	2.10	2.50	3.30	3.60	4.30	4.80	
HKLW 34	Delivery Q_{pu} (lpm)	50 Hz	1.10	1.65	2.20	2.89	3.44	4.54	4.95	5.91	6.60
		60 Hz	1.32	1.98	2.64	3.47	4.13	5.45	5.94	7.10	7.92
	Perm. pressure p_{max} (bar)	50 Hz	210	210	210	210	210	210	195	170	135
		60 Hz	210	210	210	210	210	170	155	130	115
HKLW 32	Delivery Q_{pu} (lpm)	50 Hz	2.24	3.36	4.48	5.88	7.00	9.24	10.08	12.04	13.44
		60 Hz	2.74	4.10	5.47	7.18	8.55	11.29	12.31	14.71	16.42
	Perm. pressure p_{max} (bar)	50 Hz	210	210	210	160	135	100	95	80	70
		60 Hz	210	195	145	110	90	70	65	50	45
HKLW 36	Delivery Q_{pu} (lpm)	60 Hz	2.74	4.10	5.47	7.18	8.55	11.29	12.31	14.71	16.42
	Perm. pressure p_{max} (bar)	60 Hz	210	210	210	170	140	105	100	80	75
Z	Coding for gear										
	Delivery flow coding	8,2	8,8	11,3							
	Geom. displace V_g (cm ³ /rev)	5.80	6.20	7.9							
HKLW 34	Delivery Q_{pu} (lpm)	50 Hz	7.98	8.53	10.86						
		60 Hz	9.57	10.23	13.04						
	Perm. pressure p_{max} (bar)	50 Hz	135	125	90						
		60 Hz	95	90	60						
HKLW 32	Delivery Q_{pu} (lpm)	50 Hz	16.24	17.36	22.12						
		60 Hz	19.84	21.20	27.02						
	Perm. pressure p_{max} (bar)	50 Hz	55	55	40						
		60 Hz	40	35	20						
HKLW 36	Delivery Q_{pu} (lpm)	60 Hz	19.84	21.20	27.02						
	Perm. pressure p_{max} (bar)	60 Hz	60	55	30						

b) Version with radial piston pump -- radial piston pump coding DHH

(2 pump elements PE for each)

Application: Synchron operation of two cylinders

Order example: HKL 34 D/2 - **DHH 4,4/4,4** - ... - 3x400/230V 50Hz

Table 5 a: Pressure connection P1 and P3
Dual circuit pumps with 3~phase motor
Radial piston pump **H**

Note:

Guide line figure, based on nom. rev. rating at mains frequency 50 Hz or 60 Hz.

The delivery flow rating Q_{pu} is a guide line figure, based on nom. rev. rating that will be slightly reduced dep. on load (see sect. 3.3). For notes regarding pressure p_{max} and p_1 (see sect. 3.3, table 9).The perm. pressure p_{max} correspond to motors 3x400 / 230V 60 Hz.For other voltage: $p_{max} = (pV_{g,max}/V_g)$ with $(pV_{g,max})$ from table 9 on page 14. The max. value for the hydraulic work $(pV_{g,max})$ is reduced by 10% with pumps type **HH, HZ, ZZ, DHH** or **Z-H**.

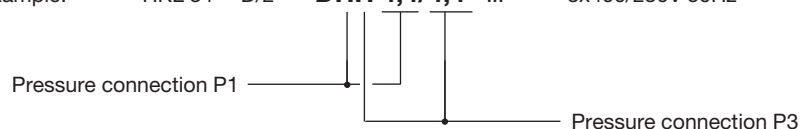
H	Coding for radial piston pump			Piston diameter (mm)								
				6	7	8	10	12	13	14	15	16
	Delivery flow coding (2-cylinder pump)			0,6	0,83	1	1,6	2,4	2,8	3,3	3,8	4,4
	Geom. displace V_g (cm ³ /rev)			0.43	0.58	0.76	1.1	1.72	2.02	2.34	2.6	3.06
HKL 34	Delivery Q_{pu} (lpm)	50Hz	0.61	0.82	1.08	1.68	2.42	2.84	3.30	3.79	4.31	
		60Hz	0.73	0.99	1.29	2.02	2.91	3.41	3.95	4.54	5.16	
	Perm. pressure p_{max} (bar)			700	700	700	560	390	330	290	250	220
HKL 32	Delivery Q_{pu} (lpm)	50Hz	1.22	1.66	2.17	3.39	4.88	5.73	6.65	7.63	8.68	
		60Hz	1.47	1.99	2.61	4.07	5.86	6.88	7.98	9.16	10.42	
	Perm. pressure p_{max} (bar)			700	700	700	475	330	280	240	210	180
HKL 38	Delivery Q_{pu} (lpm)	50Hz	0.59	0.80	1.05	1.64	2.36	2.77	3.22	3.69	4.20	
		60Hz	0.71	0.97	1.26	1.97	2.84	3.33	3.86	4.43	5.04	
	Perm. pressure p_{max} (bar)			700	700	700	560	390	330	290	250	220

Table 5 b: Pressure connection P1 and P3
Dual circuit pumps with 1~phase motor
Radial piston pump **H**

Note:

Guide line figure, based on nom. rev. rating at mains frequency 50 Hz or 60 Hz.

The delivery flow rating Q_{pu} is a guide line figure, based on nom. rev. rating that will be slightly reduced dep. on load (see sect. 3.3). For notes regarding pressure p_{max} and p_1 (see sect. 3.3, table 9).The perm. pressure p_{max} correspond to motors 1x230V 50 Hz / 1x110V 60 Hz.For other voltage: $p_{max} = (pV_{g,max}/V_g)$ with $(pV_{g,max})$ from table 9 on page 14. The max. value for the hydraulic work $(pV_{g,max})$ is reduced by 10% with pumps type **HH, HZ, ZZ, DHH** or **Z-H**.

A capacitor is mandatory for the version with 1~phase motor, which is not scope of delivery. For recommendations and notes regarding selection, see sect. 3.3 and. 5.1 i. These power packs won't start-up against pressure!

H	Coding for radial piston pump			Piston diameter (mm)								
				6	7	8	10	12	13	14	15	16
	Delivery flow coding			0,6	1,65	2,15	3,35	4,8	5,7	6,7	7,7	8,7
	Geom. displace V_g (cm ³ /rev)			0.43	0.58	0.76	1.19	1.72	2.02	2.34	2.69	3.06
HKLW 34	Delivery Q_{pu} (lpm)	50 Hz	0.59	0.80	1.05	1.64	2.36	2.77	3.22	3.69	4.20	
		60 Hz	0.71	0.97	1.26	1.97	2.84	3.33	3.86	4.43	5.04	
	Perm. pressure p_{max} (bar)	50 Hz	700	700	700	656	455	388	335	292	256	
		60 Hz	700	700	700	475	330	280	240	210	185	
HKLW 32	Delivery Q_{pu} (lpm)	50 Hz	1.20	1.64	2.14	3.34	4.81	5.65	6.55	7.52	8.56	
		60 Hz	1.47	2.00	2.61	4.08	5.88	6.90	8.00	9.19	10.45	
	Perm. pressure p_{max} (bar)	50 Hz	700	585	445	285	195	165	145	125	110	
		60 Hz	540	395	305	195	135	115	95	85	75	

c) Version with gear pump - gear pump, coding ZZ

Note: Only available in combination with tank coding 9 or 89 (table 1)!

Order example: HKL 38 89 DT/1 - **ZZ 6,9/12,3** - SS - A1 F3/160 -...- 3x400/230V 50Hz

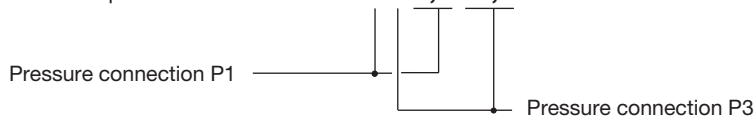

Table 6 a: Pressure connection P1 and P3:
Dual circuit pumps with 3~phase motor
gear pump - gear pump **ZZ**

Note:

Guide line figure, based on nom. rev. rating at mains frequency 50 Hz or 60 Hz.
The delivery flow rating Q_{pu} is a guide line figure, based on nom. rev. rating that will be slightly reduced dep. on load (see sect. 3.3).

For notes regarding pressure p_{max} and p_1 (see sect. 3.3, table 9).

The perm. pressure p_{max} correspond to motors 3 x 400 / 230V 50 Hz.

For other voltage: $p_{max} = (pV_{g,max}/V_g)$ with $(pV_{g,max})$ from table 9 on page 14. The max. value for the hydraulic work $(pV_{g,max})$ is reduced by 10% with pumps type **HH, HZ, ZZ, DHH** or **Z-H**.

Available combinations
ZZ 5,2/16
ZZ 6,9/12,3
ZZ 5,2/21
ZZ 6,5/16

ZZ	Coding for gear		1	2	1	2	2	2
	Delivery flow coding		5,2	6,5	6,9	12,3	16	21
	Geom. displace V_g (cm ³ /rev)		3.60	5.00	4.80	8.50	11.00	14.50
HKL 34	Delivery Q_{pu} (lpm)	50 Hz	5.08	7.05	6.77	11.99	15.51	20.45
		60 Hz	6.08	8.45	8.11	14.37	18.59	24.51
	Perm. pressure p_{max} (bar)		195	170	130	125	100	75
HKL 32	Delivery Q_{pu} (lpm)	50 Hz	10.22	14.20	13.63	24.14	31.24	41.18
		60 Hz	12.28	17.05	16.37	28.99	37.51	49.45
	Perm. pressure p_{max} (bar)		160	115	115	65	50	40
HKL 38	Delivery Q_{pu} (lpm)	50 Hz	4.95	6.88	6.60	11.69	15.13	19.94
		60 Hz	5.94	8.25	7.92	14.03	18.15	23.93
	Perm. pressure p_{max} (bar)		210	170	130	160	120	90

Table 6 b: Pressure connection P1 and P3:
Dual circuit pumps with 1~phase motor
gear pump - gear pump **ZZ**

Note:

Guide line figure, based on nom. rev. rating at mains frequency 50 Hz or 60 Hz.
The delivery flow rating Q_{pu} is a guide line figure, based on nom. rev. rating that will be slightly reduced dep. on load (see sect. 3.3).

For notes regarding pressure p_{max} and p_1 (see sect. 3.3, table 9).

The perm. pressure p_{max} correspond to motors 1x230V 50 Hz / 1x110V 60 Hz.

For other voltage: $p_{max} = (pV_{g,max}/V_g)$ with $(pV_{g,max})$ from table 9 on page 14. The max. value for the hydraulic work $(pV_{g,max})$ is reduced by 10% with pumps type **HH, HZ, ZZ, DHH** or **Z-H**.

A capacitor is mandatory for the version with 1~phase motor, which is not scope of delivery. For recommendations and notes regarding selection, see sect. 3.3 and 5.1 i. These power packs won't start-up against pressure!

ZZ	Coding for gear		1	2	1	2	2	2
	Delivery flow coding		5,2	6,5	6,9	12,3	16	21
	Geom. displace V_g (cm ³ /rev)		3.60	5.00	4.80	8.50	11.00	14.50
HKLW 34	Delivery Q_{pu} (lpm)	50 Hz	4.95	6.88	6.60	11.69	15.13	19.94
		60 Hz	5.94	8.25	7.92	14.03	18.15	23.93
	Perm. pressure p_{max} (bar)	50 Hz	195	155	135	90	70	50
		60 Hz	155	110	115	65	50	35
HKLW 32	Delivery Q_{pu} (lpm)	50 Hz	10.08	14.00	13.44	23.80	30.80	40.60
		60 Hz	12.31	17.10	16.42	29.07	37.62	49.59
	Perm. pressure p_{max} (bar)	50 Hz	95	68	71	40	31	24
		60 Hz	65	45	45			

2.2.3 Dual circuit pumps with separate connection pedestals

Note: Only available in combination with tank coding **8** or **89** (table 1)!

Order example 1: HKL W 328 T/1 - **Z5,2** - H0,88 - A1/120 - A1/350 - - 1x110 V 60Hz

Order example 2: HKL 3889 DT/1 - **Z8,8** - H0,57 - B1/100 - 1 - 31D - G24 - A1/700 - 3x400/230 V 50Hz



Table 7 a: Pressure connection P1
Dual circuit pumps with 3-phase motor
gear pump **Z**

Note:

Guide line figure, based on nom. rev. rating at mains frequency 50 Hz or 60 Hz.

The delivery flow rating Q_{pu} is a guide line figure, based on nom. rev. rating that will be slightly reduced dep. on load (see sect. 3.3).

For notes regarding pressure p_{max} and p_1 (see sect. 3.3, table 9).

The perm. pressure p_{max} correspond to motors 3x400 / 230V 60 Hz.

For other voltage: $p_{max} = (pV_{g,max}/V_g)$ with $(pV_{g,max})$ from table 9 on page 14 The max. value for the hydraulic work $(pV_g)_{max}$ is reduced by 10% with pumps type **HH, HZ, ZZ, DHH** or **Z-H**.

Z	Coding for gear													
	Delivery flow coding		1,1	1,7	2	2,7	3,5	4,5	5,2	6,4	6,9	8,2	8,8	11,3
	Geom. displace V_g (cm ³ /rev)		0.80	1.20	1.60	2.10	2.50	3.30	3.60	4.30	4.80	5.80	6.20	7.90
HKL 34	Delivery Q_{pu} (lpm)	50 Hz	1.13	1.69	2.26	2.96	3.53	4.65	5.08	6.06	6.77	8.18	8.74	11.14
		60 Hz	1.35	2.03	2.70	3.55	4.23	5.58	6.08	7.27	8.11	9.80	10.48	13.35
	Perm. pressure p_{max} (bar)		210	210	210	210	210	210	210	170	130	130	125	100
HKL 32	Delivery Q_{pu} (lpm)	50 Hz	2.27	3.41	4.54	5.96	7.10	9.37	10.22	12.21	13.63	16.47	17.61	22.44
		60 Hz	2.73	4.09	5.46	7.16	8.53	11.25	12.28	14.66	16.37	19.78	21.14	26.94
	Perm. pressure p_{max} (bar)		210	210	210	210	210	175	160	130	120	95	90	55
HKL 38	Delivery Q_{pu} (lpm)	50 Hz	1.10	1.65	2.20	2.89	3.44	4.54	4.95	5.91	6.60	7.98	8.53	10.86
		60 Hz	1.32	1.98	2.64	3.47	4.13	5.45	5.94	7.10	7.92	9.57	10.23	13.04
HKL 38 V	Perm. pressure p_{max} (bar)		210	210	210	210	210	195	185	170	150	135	120	

Table 7 b: Pressure connection P1
Dual circuit pumps with 1-phase motor
gear pump **Z**

Note:

Guide line figure, based on nom. rev. rating at mains frequency 50 Hz or 60 Hz.

The delivery flow rating Q_{pu} is a guide line figure, based on nom. rev. rating that will be slightly reduced dep. on load (see sect. 3.3).

For notes regarding pressure p_{max} and p_1 (see sect. 3.3, table 9).

The perm. pressure p_{max} correspond to motors 1x230V 50 Hz / 1x110V 60 Hz.

For other voltage: $p_{max} = (pV_{g,max}/V_g)$ with $(pV_{g,max})$ from table 9 on page 14. The max. value for the hydraulic work $(pV_g)_{max}$ is reduced by 10% with pumps type **HH, HZ, ZZ, DHH** or **Z-H**.

A capacitor is mandatory for the version with 1-phase motor, which is not scope of delivery. For recommendations and notes regarding selection, see sect. 3.3 and 5.1 i. These power packs won't start-up against pressure!

Z	Coding for gear													
	Delivery flow coding		1,1	1,7	2	2,7	3,5	4,5	5,2	6,4	6,9	8,2	8,8	11,3
	Geom. displace V_g (cm ³ /rev)		0.80	1.20	1.60	2.10	2.50	3.30	3.60	4.30	4.80	5.80	6.20	7.90
HKLW 34	Delivery Q_{pu} (lpm)	50 Hz	1.10	1.65	2.20	2.89	3.44	4.54	4.95	5.91	6.60	7.98	8.53	10.86
		60 Hz	1.32	1.98	2.64	3.47	4.13	5.45	5.94	7.10	7.92	9.57	10.23	13.04
	Perm. pressure p_{max} (bar)	50 Hz	210	210	210	210	210	210	195	170	135	135	125	90
		60 Hz	210	210	210	210	210	170	155	130	115	95	90	60
HKLW 32	Delivery Q_{pu} (lpm)	50 Hz	2.24	3.36	4.48	5.88	7.00	9.24	10.08	12.04	13.44	16.24	17.36	22.12
		60 Hz	2.74	4.10	5.47	7.18	8.55	11.29	12.31	14.71	16.42	19.84	21.20	27.02
	Perm. pressure p_{max} (bar)	50 Hz	210	210	210	160	135	100	95	80	70	55	55	40
		60 Hz	210	195	145	110	90	70	65	50	45	40	35	20

Circuitry symbol acc. to order example 1:

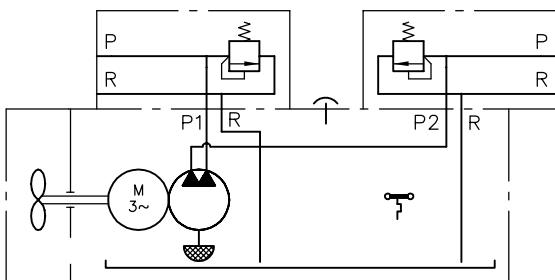

Circuitry symbol acc. to order example 2:

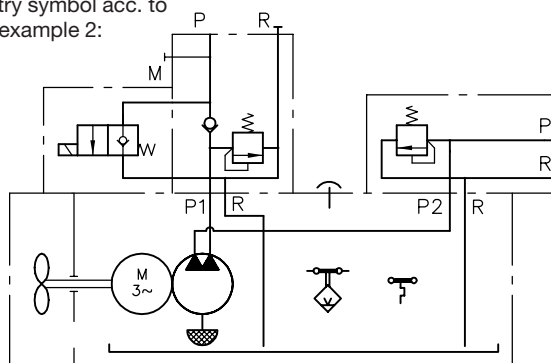

Continuation sect. 2.2.3

Order example 1: HKL W 328 T/1 - Z5,2 - **H 0,88** - A1/120 - A1/359 - - 1x110 V 60Hz
 Order example 2: HKL 3889 DT/1 - Z8,8 - **H 0,57** - B1/100 - 1 - 31D - G24 - A1/700 - 3x400/230 V 50Hz

Pressure connection P1
table 7

Table 8 a: Pressure connection P2
Dual circuit pumps with 3~phase motor
Radial piston pump **H**

Note:

Guide line figure, based on nom. rev. rating at mains frequency 50 Hz or 60 Hz.

The delivery flow rating Q_{pu} is a guide line figure, based on nom. rev. rating that will be slightly reduced dep. on load (see sect. 3.3).

For notes regarding pressure p_{max} and p_1 (see sect. 3.3, table 9).

The perm. pressure p_{max} correspond to motors 3x400 / 230V 60 Hz.

For other voltage: $p_{max} = (pV_g)_{max}/V_g$ with $(pV_g)_{max}$ from table 9 on page 14. The max. value for the hydraulic work $(pV_g)_{max}$ is reduced by 10% with pumps type **HH, HZ, ZZ, DHH** or **Z-H**.

H	Coding for radial piston pump	Piston diameter (mm)							
		4	4/5	5	6	7	8	9	
	Delivery flow coding	0,37	0,47	0,57	0,88	1,12	1,42	1,82	
	Geom. displace V_g (cm ³ /rev)	0.25	0.32	0.39	0.57	0.77	1.01	1.27	
HKL 34	Delivery Q_{pu} (lpm)	50 Hz	0.35	0.45	0.55	0.80	1.09	1.42	1.79
		60 Hz	0.42	0.54	0.66	0.96	1.30	1.70	2.15
	Perm. pressure p_{max} (bar)	700	700	700	700	700	700	550	
HKL 32	Delivery Q_{pu} (lpm)	50 Hz	0.71	0.90	1.12	1.61	2.19	2.86	3.61
		60 Hz	0.86	1.08	1.34	1.93	2.62	3.43	4.34
	Perm. pressure p_{max} (bar)	700	700	700	700	700	570	450	
HKL 38	Delivery Q_{pu} (lpm)	50 Hz	0.35	0.44	0.54	0.78	1.06	1.38	1.75
		60 Hz	0.41	0.52	0.65	0.93	1.27	1.66	2.10
HKL 38 V	Perm. pressure p_{max} (bar)	700	700	700	700	700	700	700	

Table 8 b: Pressure connection P2
Dual circuit pumps with 1~phase motor
Radial piston pump **H**

Note:

Guide line figure, based on nom. rev. rating at mains frequency 50 Hz or 60 Hz.

The delivery flow rating Q_{pu} is a guide line figure, based on nom. rev. rating that will be slightly reduced dep. on load (see sect. 3.3).

For notes regarding pressure p_{max} and p_1 (see sect. 3.3, table 9).

The perm. pressure p_{max} correspond to motors 1x230V 50 Hz / 1x110V 60 Hz.

For other voltage: $p_{max} = (pV_g)_{max}/V_g$ with $(pV_g)_{max}$ from table 9 on page 14. The max. value for the hydraulic work $(pV_g)_{max}$ is reduced by 10% with pumps type **HH, HZ, ZZ, DHH** or **Z-H**.

A capacitor is mandatory for the version with 1~phase motor, which is not scope of delivery. For recommendations and notes regarding selection, see sect. 3.3 and. 5.1 i. These power packs won't start-up against pressure!

H	Coding for radial piston pump	Piston diameter (mm)							
		4	4/5	5	6	7	8	9	
	Delivery flow coding	0,37	0,47	0,57	0,88	1,12	1,42	1,82	
	Geom. displace V_g (cm ³ /rev)	0.25	0.32	0.39	0.57	0.77	1.01	1.27	
HKLW 34	Delivery Q_{pu} (lpm)	50 Hz	0.35	0.44	0.54	0.78	1.06	1.38	1.75
		60 Hz	0.41	0.52	0.65	0.93	1.27	1.66	2.10
	Perm. pressure p_{max} (bar)	50 Hz	700	700	700	700	700	700	610
		60 Hz	700	700	700	700	700	560	440
HKLW 32	Delivery Q_{pu} (lpm)	50 Hz	0.70	0.89	1.10	1.58	2.16	2.81	3.56
		60 Hz	0.86	1.09	1.34	1.93	2.63	3.44	4.35
	Perm. pressure p_{max} (bar)	50 Hz	700	700	700	600	440	335	265
		60 Hz	700	700	590	410	300	230	180

3. Further characteristic data

3.1 General

Nomenclature	Constant delivery pump		
Design	Valve controlled radial piston pump or gear pump		
Direction of rotation	Radial piston pump -- Any		
	Gear pump - Counter clock-wise, as indicated by an arrow on the fan shroud. It is therefore necessary to check the rotation direction of the motor. The fan wheel has to rotate counter clockwise after briefly starting the motor when looking through the perforation of the fan shroud.		
Speed range	Radial piston pump H: 200 ... 3500 min ⁻¹		
	Gear pump	Z 1.1 ... Z 3.5: 500 ... 4500 min ⁻¹	Z 4.5 ... Z 5.2: 500 ... 3200 min ⁻¹
		Z 6.4 ... Z 6.9: 500 ... 2400 min ⁻¹	Z 8.2 ... Z 8.8: 500 ... 1800 min ⁻¹
		Z 11.3: 500 ... 1500 min ⁻¹	Z 6.5 ... Z 21: 500 ... 3500 min ⁻¹

Mounting	via four supports with holes Ø9 mm, see also sect. 5.2.6			
Mass (weight) (without hydraulic fluid)	Basic type	H	Z	HZ, HH, DHH, Z - H
	HKL 3	19.7 kg	19.7 kg	20.5 kg
	HKLW 3.			
	HKL 3.7	21.9 kg	21.9 kg	22.7 kg
	HKLW 3.7			
	HKL 3.8	27 kg	27 kg	27.5 kg
	HKLW 3.8			
	HKL 3.9	21.5 kg	21.5 kg	22.3 kg
	HKLW 3.9			
	HKL 3.79	23.7 kg	23.7 kg	24.5 kg
	HKLW 3.79			
	HKL 3.89	28.8 kg	28.8 kg	29.3 kg
	HKLW 3.89			

For mass (weight) of the connection blocks and valve banks, see the respective pamphlets (see listing in sect. 5.1 k and 5.1 l)

Pipe connection only via directly mounted connection blocks, see selection table in section 5.1 k
Basic pump: Port hole pattern see section 4.3

Running noise

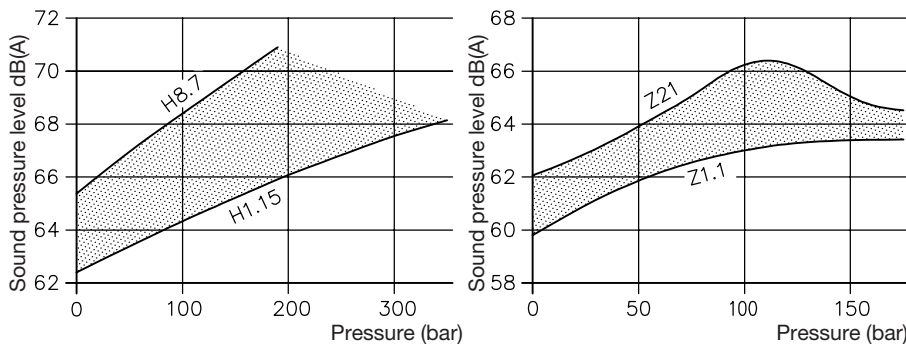

Measuring conditions:
Work room, interference level approx. 50 dB(A); Measuring point 1m above the floor; 1 m object clearance, pump fixed with 4 silentblocs Ø40x30 65 Shore, (co. silentbloc No. 20291/V).

Measuring device:
Precision sound pressure level measuring instrument IEC 651class I

Viscosity of the oil: Approx. 60 mm²/s

Note:

Pumps with smaller delivery flows tend as a rule to the lower, whereas larger ones tend to the upper limit. The noise level of dual circuit pumps are similar to the one of single circuit radial piston pumps, if the total delivery flow is rather identical.

3.2 Hydraulic

Pressure	Delivery side (outlet ports P, P1 und P3) depending on pump design and delivery flow, see sect. 2.2 Suction side (inside the tank): ambient pressure. Not suitable for charging.		
Start-up against pressure	Versions with 3~phase motor will start-up against pressure p _{max} ! Whereas versions with 1~phase motor will start-up only against slight pressure (see note in sect. 5)!		
Pressure fluid	Hydraulic oil conforming DIN 51 524 part 1 to 3; ISO VG 10 to 68 conforming DIN 51 519 Opt. operation range: Radial piston pump H: 10 ... 500 mm ² /s Gear pump Z: 20 ... 100 mm ² /s Viscosity range: min. approx. 4; max. approx. 800 mm ² /s Also suitable are biologically degradable pressure fluids type HEES (Synth. Ester) at service temperatures up to approx. +70°C. Electrically hazardous: Any fluid types containing water must not be used (short-cut).		
Temperature	Ambient: approx. -40 ... +60°C; Fluid: -25 ... +80°C. Note the viscosity range ! Permissible temperature during start: -40°C (observe start-viscosity!), as long as the service temperature is at least 20K higher for the following operation. Biologically degradable pressure fluids: Observe manufacturer's specifications. By consideration of the compatibility with seal material not over +70°C.		

Filling and usable volume	Tank size	Filling volume	Usable filling volume	
Coding	V _{filling}	V _{usable} (coding H, Z)	V _{usable} (coding HZ, HH, DHH, Z - H)	
--	3.7 l	1.7 l	1.7 l	
7	4.1 l	2.1 l	1.7 l	
8	5.5 l	2.6 l	1.7 l	
9	11.2 l	8.2 l	8.2 l	
79	11.6 l	8.6 l	8.2 l	
89	13 l	9.1 l	8.2 l	

3.3 Electrical data

The drive motor and pump form a closed, not separable unit, see description section 1.

Connection	<ul style="list-style-type: none"> ● Version with terminal box, WAGO CAGE CLAMP®S, cable 1.5 mm² ... 3 mm² (Cable gland M20x1.5 is customer furnished) ● Version with central plug (Co. HARTING), cable 1.5 mm² ● Version with terminal box and blade type terminals, blade type terminals (female) 6.3 (Co. AMP) (cable gland M20x1.5 is customer furnished)
Protection class	IP 54 conf. IEC 60529, apply to the complete hydraulic power pack (as a reference protection class to pure electrical machinery)
Safety class	VDE 0100 Safety class 1
Insulation	Design conf. EN 60664-1 <ul style="list-style-type: none"> ● for mains with 4 or 3 conductors L1~L2-L3-PE (3-phase mains) with grounded neutral point up to 500V AC nom. phase voltage conductor - conductor ● for mains with 4 or 3 conductors L1~L2-L3 (3-phase mains) without grounded neutral point up to 300V AC nom. phase voltage conductor - conductor ● for 1-phase mains with 2 conductors L-N up to 300V AC nom. voltage.

Table 9: Motor data

Type	Nom. voltage and mains frequency U_N (V), f (Hz)	Nominal power P_N (kW)	Nom. speed n_N (rpm)	Nom. current I_N (A)	Start current ratio I_A / I_N	Power factor $\cos \varphi$	Rec. operating capacitor C_B (μF)	max. hydraulic work $(pV_g)_{\max}$ (bar/cm ³)
HKL 34	3x400/230 V 50 Hz $\Upsilon\Delta$	1.5	1410	3.5/6.1	5.3	0.83		1150
HKL34 V	3x460/265V 60 Hz $\Upsilon\Delta$	1.8	1690	3.6/6.2	5.0	0.83		1150
	3x200 V 50 Hz Υ	1.5	1410	7.2	5.0	0.81		1050
	3x220 V 60 Hz Υ	1.5	1700	7.2	5.2	0.87		840
HKL 32	3x400/230 V 50 Hz $\Upsilon\Delta$	1.5	2840	3.3/5.8	6.3	0.86		600
	3x460/265 V 60 Hz $\Upsilon\Delta$	1.8	3410	3.4/5.9	6.1	0.86		600
	3x200 V 50 Hz Υ	1.5	2840	6.6	6.4	0.86		580
	3x220 V 60 Hz Υ	1.5	3440	6.0	7.0	0.86		400
HKL 38	3x400/230 V 50 Hz $\Upsilon\Delta$	2.2	1375	4.6/8.0	5.4	0.9		1470
HKL 38 V	3x460/265 V 60 Hz $\Upsilon\Delta$	2.65	1650	4.6/8.0	5.0	0.9		1470
HKLW 34	1x230 V 50 Hz \perp	1.5	1375	10.1	3.3	0.94	40	820
	1x110 V 60 Hz \perp	1.5	1690	20	4.5		120	590
	1x115 V 50 Hz \perp	1.5	1375	21	3.3	0.94	120	680
	1x220 V 60 Hz \perp	1.5	1690	10	4.5	0.94	30	790
HKLW 32	1x230 V 50 Hz \perp	1.5	2800	10.5	3.3	0.94	25	355
	1x110 V 60 Hz \perp	1.5	3420	20.5	4.5	0.95	110	240
HKLW 36	1x110 V 60 Hz \perp	2.0	3420	26	4.5	0.95	120	380

Note :

- The current consumption of the motor depends strongly on its load. The nominal figures apply strictly to one operating point only. The pump may work continuously against pressure p_1 , see sect. 2.2 (= continuous operation S1). Up to 1.8s of the nominal power of the motor can be exploited during load / no load operation (= operation mode S2, S3 or S6). The increased heat built-up under these conditions gets intensively radiated during the idle or stand-still periods.
- The respective current consumption can be estimated via the middled and max. figures for the hydraulic work $(pV_g)_m$ and $(pV_g)_{\max}$.
- The max. value for the hydraulic work $(pV_g)_{\max}$ is reduced by 10% with pumps type **Z, HH, HZ, ZZ, DHH** or **Z-H**.
- The respective load is determining for the current consumption of dual circuit pumps. The hydraulic work of the individual circuits have to be determined and added up.

All pressure outlets pressureized:



Dual circuit pumps $(pV_g)_{\text{rechn.}} = p_1 V_{g1} + p_3 V_{g3}$

One pressure outlet is pressureized, the other one in idle circulation mode:

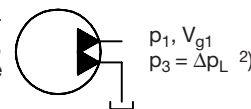

Dual circuit pumps $(pV_g)_{\text{calc}} = p_1 V_{g1} + \Delta p_L V_{g3}$

- Versions with 1-phase motors. The actual current consumption also depends on the size of the operating capacitor. The operating capacitor is not scope of delivery. For selection, see sect. 5.1 e
- Tension tolerances: $\pm 10\%$ (IEC 38), at 3 x 460/265V 60 Hz $\pm 5\%$
It is possible to use the power pack with reduced voltage, but this will cause a reduced performance, see sect. 5.1 e!

Current consumption

HKL 34

HKL 38

Operating voltage 3 x 400/230V 50 Hz $\Upsilon\Delta$
3 x 460/265V 60 Hz $\Upsilon\Delta$

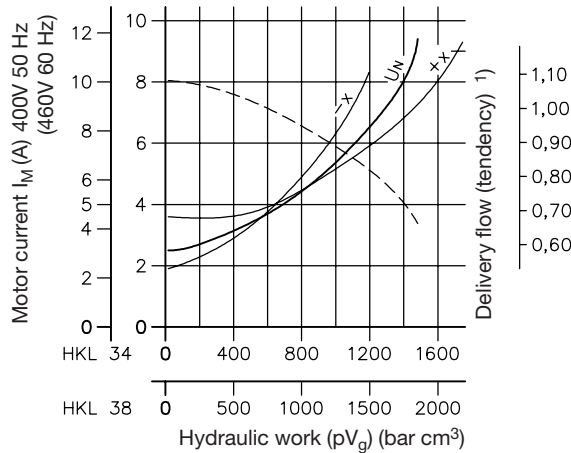

HKL 32

Operating voltage 3 x 400/230V 50 Hz $\Upsilon\Delta$
3 x 460/265V 60 Hz $\Upsilon\Delta$

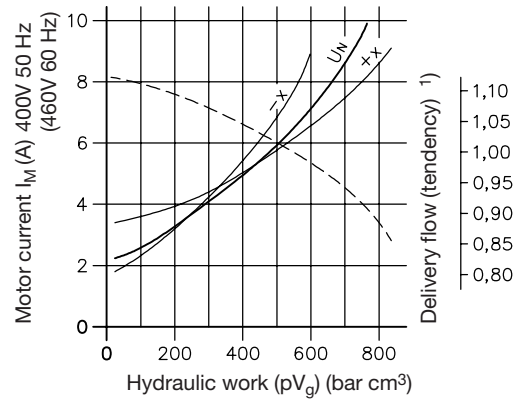

HKLW 34

Operating voltage 1 x 230V 50 Hz
1 x 110V 60 Hz

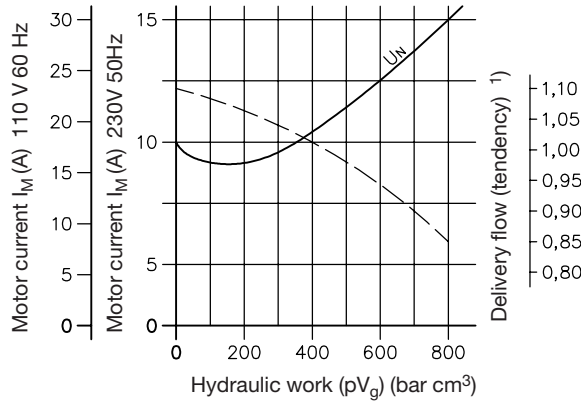

HKLW 32

HKLW 36

Operating voltage 1 x 230V 50 Hz
1 x 110V 60 Hz

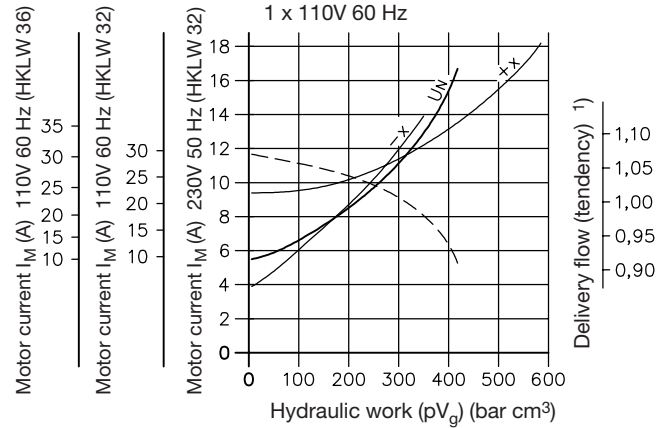

1) 1.0 = Q_{Pu} acc. to table 2 ... 8

Temperature switch

Coding T

Technical data:

Bimetallic switch

Type HKLW = winding protective switch

Type HKL = temperature switch, mounted separately



Signaling takes place 80°C ± 5K (Kelvin) (coding T)

60°C ± 5K (coding T60)

Max. voltage 250 V 50/60 Hz

Nom. current ($\cos \varphi \sim 0.6$) 1.6 A

Max. current at 24 V ($\cos \varphi = 1$) 1.5 A

Connection - in the terminal box / plug Co. HARTING

Float switch

Coding D, S

Technical data:

Switching performance DC/AC 60 W/ 60 VA

Max. current DC/AC 0.8 A ($\cos \varphi = 1$)

Max. voltage 230 V 50/60 Hz

A protective circuitry is mandatory at inductive loads!

D (NC-contact) **S** (NO-contact)

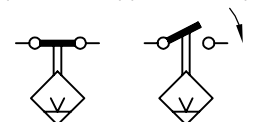

4. Unit dimensions

4.1 Mounting, hole pattern

All dimensions are in mm and are subject to change without notice!

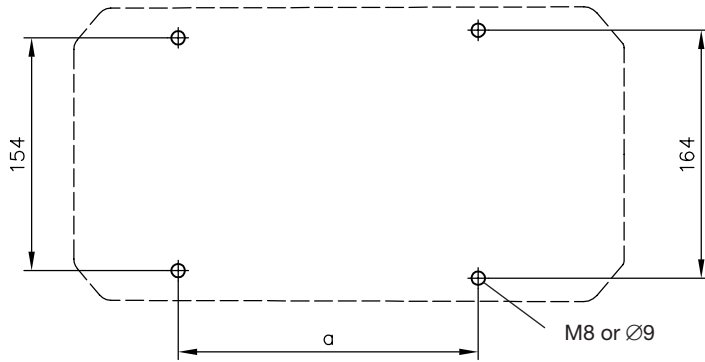

	a
HKL 3. HKLW 3.	198.5
HKL 3.7 HKLW 3.7	223.5
HKL 3.8 HKLW 3.8	316.5
HKL 3.9 HKLW 3.9	259
HKL 3.79 HKLW 3.79	284
HKL 3.89 HKLW 3.89	377

Recommended fastening



4.2 Basic pump type HKL and HKLW

Type HKL 3., HKL 3.8
Type HKL W 3., HKLW 3.8

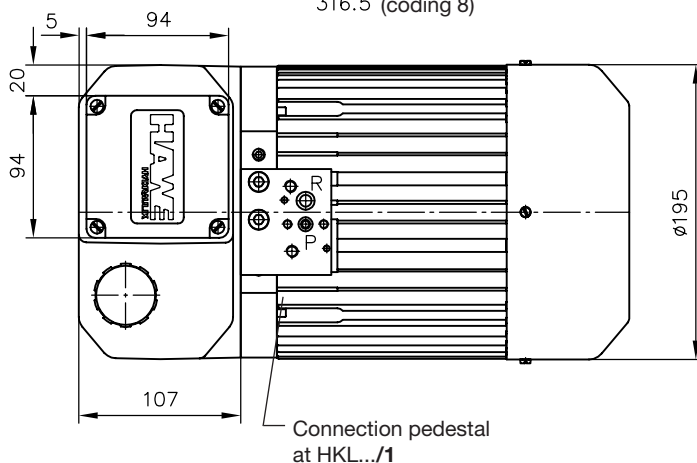
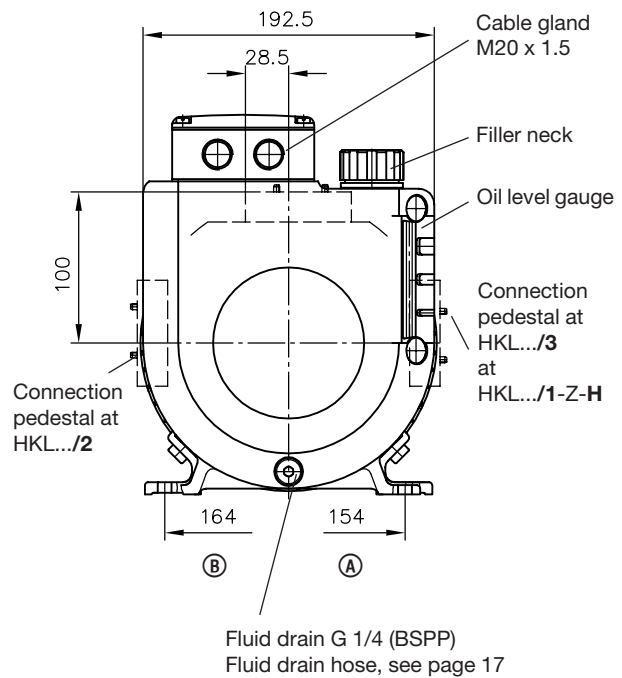
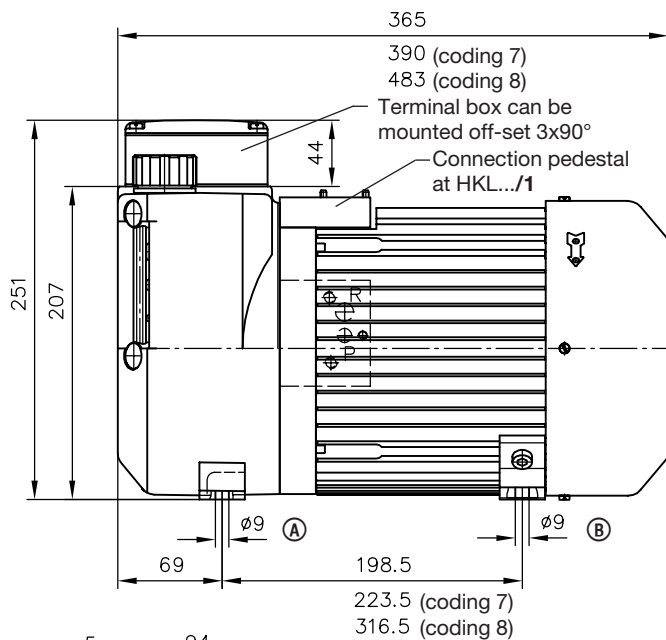

Electrical connection
Coding P, P1, see page 17

Continuation 4.2 Basic pump type HKL and HKLW

Coding P1, FP1

Coding P2, FP2

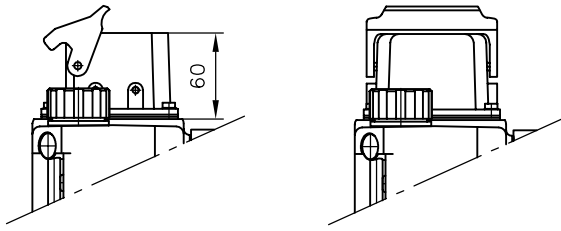

Type HKL 3.9, HKL 3.89
Type HKL W 3.9, HKLW 3.89

For missing dimensions, see page 16

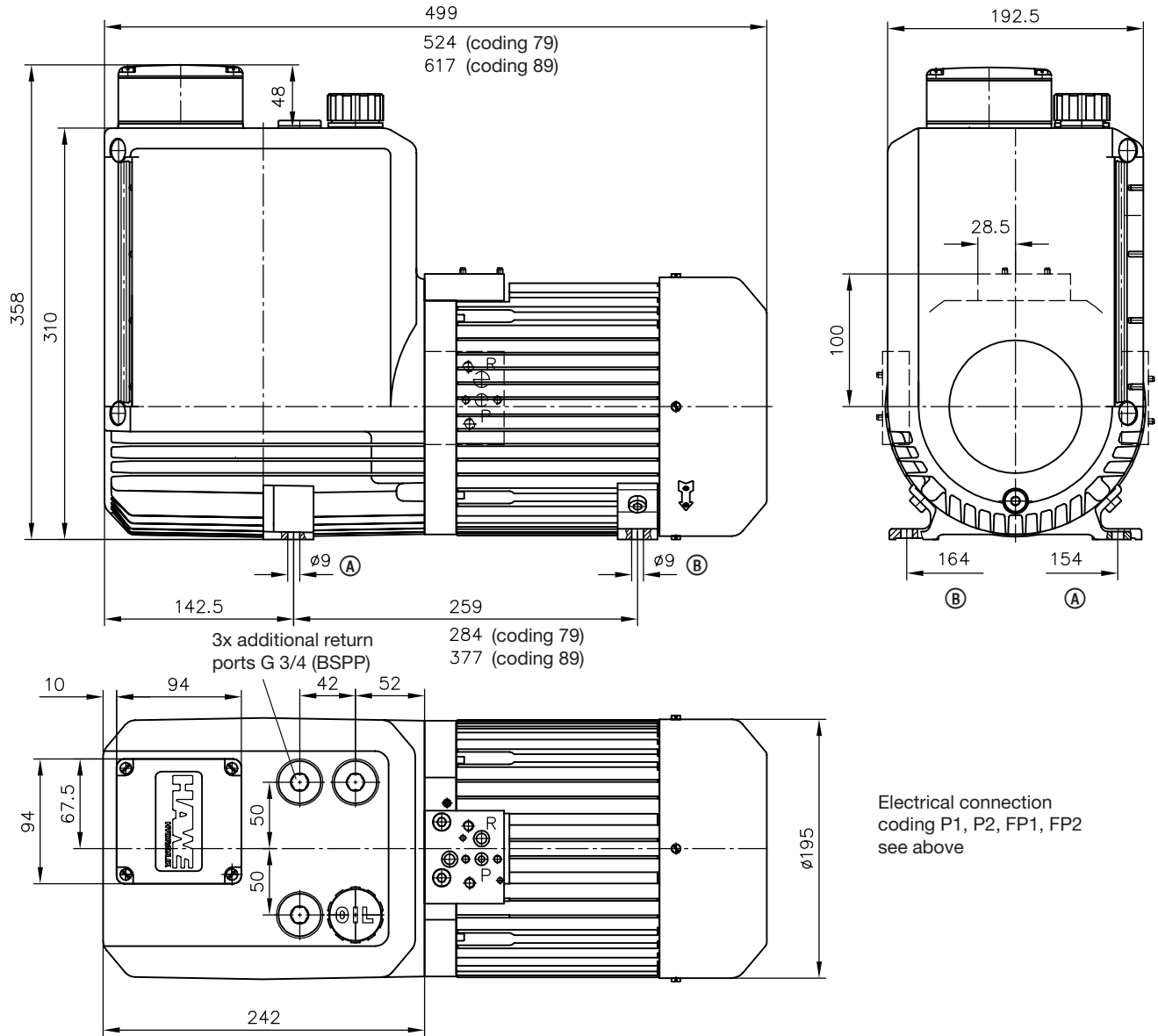

Fluid drain hose coding **G 1/4* x 300**
G 1/4* x 500

Fluid drain hose coding **G 1/4* W x 300**
G 1/4* W x 500

*BSPP

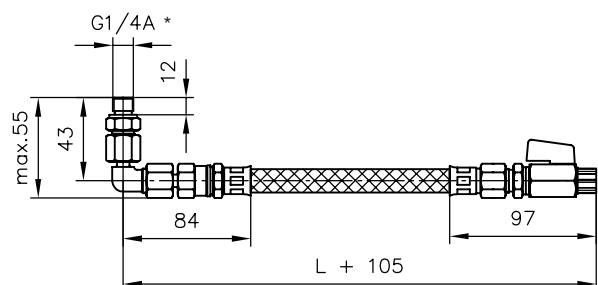
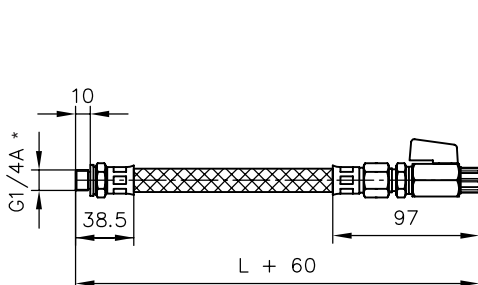

4.3 Electrical and hydraulical connection

Hydraulical

Single circuit pump
(sect. 2.2.1 table 2)

Dual circuit pump
with a separate
connection pedestal
(sect. 2.2.3,
table 7 and 8)

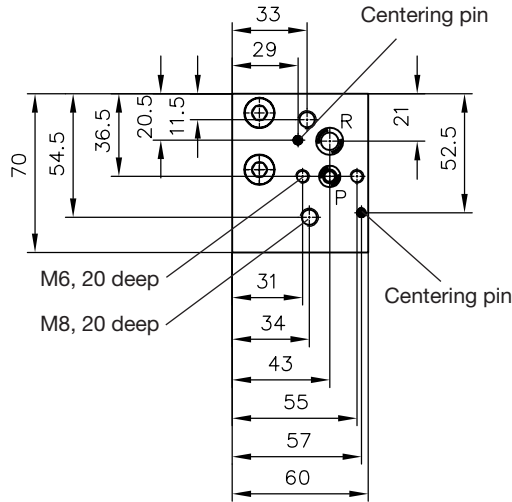

Dual circuit pump
common connection
pedestal (sect. 2.2.2,
table 3 ... 6)
For missing dimensions,
see above!

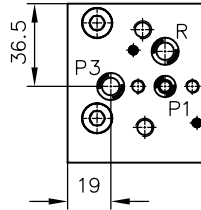

Ports at a customer furnished connection block

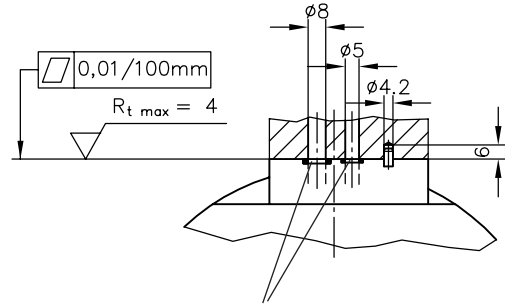

Sealing of ports:
P and P1 = Kantseal 6.07x1.68 NBR 90 Sh
P3 and R = 8x2 NBR 90 Sh

Electrical

Terminal box (without coding)
WAGO CAGE CLAMP®S, cable 1.5 mm² ... 3 mm²

3~phase motor

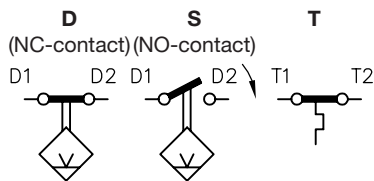
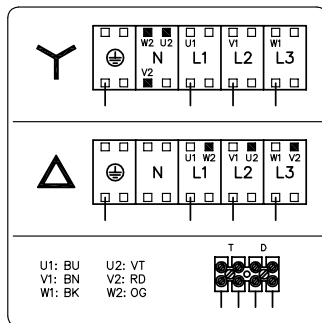

1~phase motor

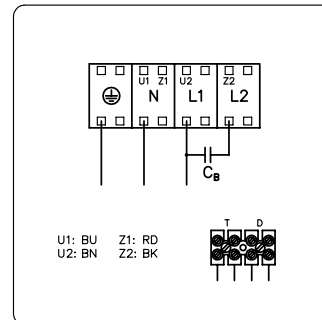

C_B - Operating capacitor is not
scope of delivery

Coding **P1, P2, FP1, FP2**
 Plug HAN 10 E Co. HARTING

3~phase motor

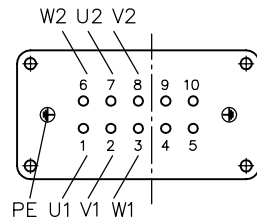

1~phase motor

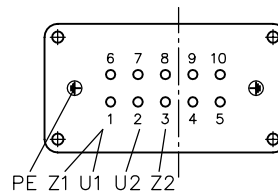

C_B - Operating capacitor is not scope of delivery

Electrical connection at the user (via the plug)

3~phase motor Υ

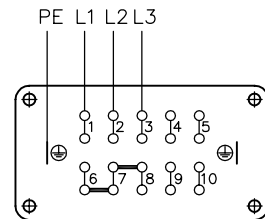

3~phase motor Δ

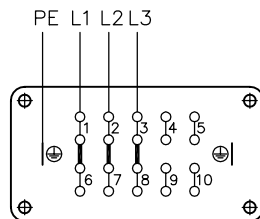

1~phase motor

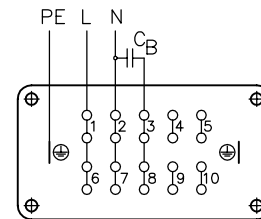

Coding **D, S**

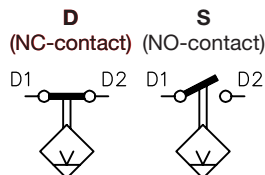
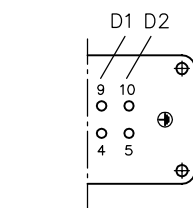

Coding **T**

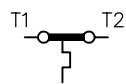
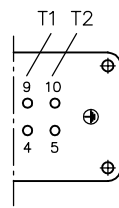

Coding **DT, ST**

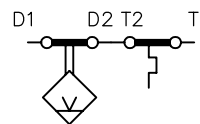
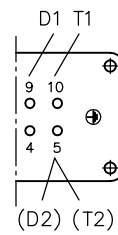

Coding **D - T, S - T**

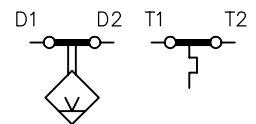
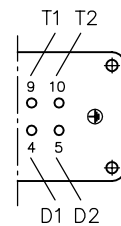

Coding **F**

Blade type terminals, blade type terminals (female) 6.3 AMP

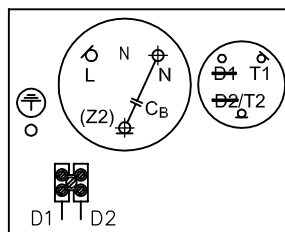
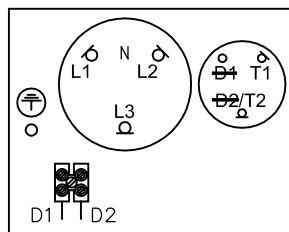

C_B - Operating capacitor is not scope of delivery

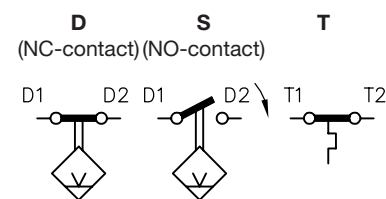

5. Appendix

5.1 Notes regarding selection

The following shows how to select a suitable hydraulic power pack with directly mounted valves. Usually an optimum solution is found when the following iteration steps have been passed.

a) Creation of a function diagram

The necessary or desired functions (hydraulically actuated) are the base for the function diagram.

b) Specification of pressure and flow

- Dimensioning and selection of the hydraulic consumers according to the required forces
- Calculation of the individual flows depending on the desired speed profiles

Note:

Take into account the necessary time for return for spring loaded clamping cylinders!

The return time of spring loaded clamping cylinders at time sensitive clamping applications, can often be even more long, than the time for clamping. In these cases, the strengths of the return spring exclusively determines the return times here. They force the piston back to its idle position opposed by the back pressure caused by valves and pipes. This has to be taken into account when dimensioning hoses, tubes and valves.

- Calculation of the individual necessary operation pressures
- Calculation of the max. necessary (pump) delivery flow – Q (lpm)
- Calculation of the max. necessary operating (system) pressure – p_{max} (bar)

c) Creation of the hydraulic circuit diagram

- Criteria:
 - Single circuit system
 - Dual circuit system with independently operated hydraulic circuits
 - Dual circuit system with one joint hydraulic circuit (e.g. press brakes or hydraulic tools with high-/low pressure or handling systems with rapid traverse and creeping)
 - Utilization of a hydraulic accumulator for brief support of the pump delivery

d) Creation of a time/load-diagram based on the function diagram

- The operation mode of the hydraulic power pack is selected according to this time/load-diagram
 - calculation of %ED
 - S1 – permanent operation (detailed evaluation for compact power packs required)
 - S2 – Short time operation
 - S3 – ON/OFF service
 - S6 – Permanent operation with intermittent load

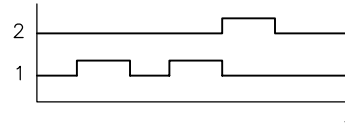

$$Q \text{ (lpm)} = 0.06 \cdot A \text{ (mm}^2\text{)} \cdot v \left(\frac{\text{m}}{\text{s}} \right)$$

$$p \text{ (bar)} = \frac{10 \cdot F \text{ (N)}}{A \text{ (mm}^2\text{)}}$$

Q - flow
p - pressure
A - area
v - speed
F - force

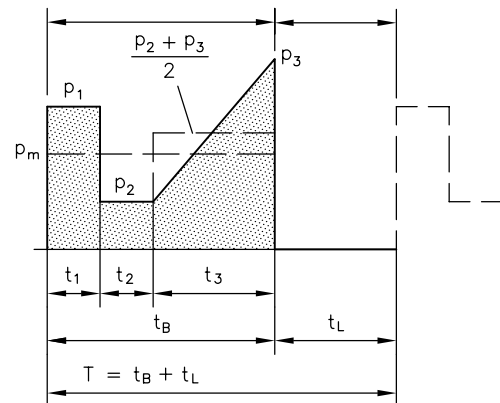

e) Selection of a hydraulic power pack

- Selection of the basic type based on the power supply
 - 3~phase mains type HKL
 - 1~phase mains type HKLW
- Motor selection
 - Voltage tolerances:
 - ±10% (IEC 38), at 3 x 460/265V 60 Hz ±5%
 - A 3-phase motor for 400 V 50 Hz can be used also at mains 460 V 60 Hz without any restrictions. 1~phase motors can be used only at mains where the nom. voltage and frequency specifications are apparent.
 - Operation with reduced voltage is possible, but there will be performance restrictions
 - $p_{max\ red} = p_{max} \cdot k$
 - p_{max} (bar) – max. operating pressure according to the selection tables
 - $p_{max\ red}$ (bar) – reduced max. operating pressure
 - k – Correction factor from diagram
- Version with moulded stator
 - Intended for use at hydraulic circuits where the hydraulic fluid contains up to 0.3% water.
- Electrical connection
 - The cable feedthrough especially sealed with coding F, FP1 and FP2 (table 1). This enable the power pack to be positioned in tilted position or to be heated.
- Selection of the pump layout (radial piston pump, gear pump, pump combination)
- Selection of the pump delivery coding taking into account the respective perm. operating pressure of the design and selection of basic type and motor size
- Assessing the noise level acc. to the diagrams in sect. 3.1

relative duty cycle

$$\%ED = \frac{t_B}{t_B + t_L} \cdot 100$$

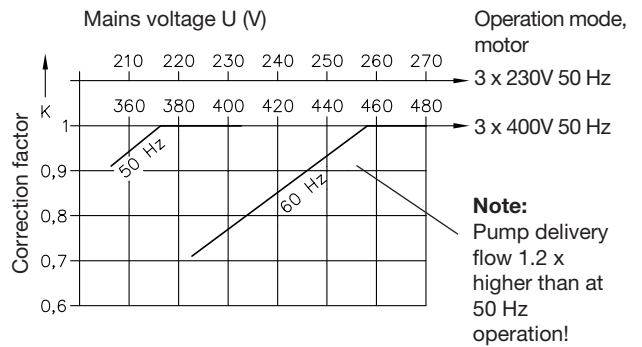

f) Calculation of the hydraulic work

- Calculation of the middled pressure
- Calculation of the middled hydraulic work (middled oper. pressure x delivery flow)
- Calculation of the max. hydraulic work (max. oper. pressure x delivery flow)

p_m (bar) = calculated, middled pressure per cycle during while load is applied

$$t_B = t_1 + t_2 + t_3 + \dots$$

$$p_m = \frac{1}{t_B} \left(p_1 \cdot t_1 + p_2 \cdot t_2 + \frac{p_2 + p_3}{2} \cdot t_3 + \dots \right)$$

$p_m V_g$ = Middled hydraulic work of the pump

V_g = geom. displacement acc. to tables in sect. 2.2

$$p V_{g\ max} \text{ (bar cm}^3\text{)} = p_{max} \cdot V_g$$

g) Determining the heat built-up

Attention: Observe the max. perm. fluid temperature of 80°C!

The persistent service temperature is reached after approximately one hour of operating time.

Influence-factors:

- Pressure distribution during the load duration (middled pressure)
- share of the idle period
- additional throttle losses, when exceeding usual figures (approx. 30%) of back pressure for pipes and valves. These influences only have to be taken into account if they are effective for a longer period within the operating cycle (load duration). This may be e.g. working against the pressure limiting valve (loss 100%)

The two most essential parameter, middled hydraulic work of the pump ($p_m V_g$) and load duration per operating cycle (%ED) are usually sufficient for a rough re-check of the expected persistent fluid service temperature.

The persistent over temperature will be 15% lower with tanks coding 8 and 89.

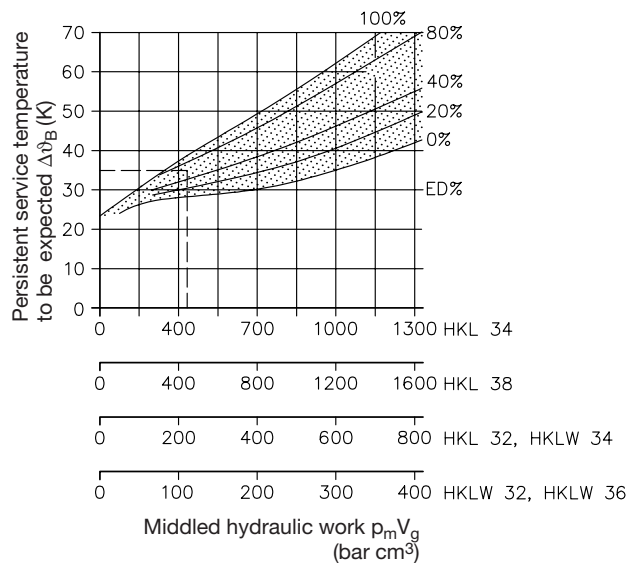

$$\vartheta_{oil\ B} = \Delta\vartheta_B + \vartheta_U$$

$\Delta\vartheta_B$ (K) - Excess temperature after applied load, diagram

ϑ_U (K) - Ambient temperature in the installation area

$\vartheta_{oil\ B}$ (°C) - Persistent service temperature of the oil filling

Attention: Observe the max. fluid temperature of 80°C!

h) Determining the max. current consumption

see curves in sect. 3.3

For setting of the motor protective switch, see sect. 5.2 c

i) Selection of the proper operation capacitor with type HKLW

A capacitor is mandatory for the version with 1-phase motor. The recommendations in sect. 3.3 table 9 ensure that the max. pressure rating specified are achieved.

The electric loss can be minimized by utilizing a smaller capacitor (- 30%) as long as only 75% of the specified max. hydraulic work (pV_g) is employed

Note: The capacitor is not scope of delivery.

Selection of the capacitor

Motor voltage	Reference voltage
1 x 230V 50 Hz	400V DB
1 x 220V 60 Hz	
1 x 110V 60 Hz	230V DB
1 x 115V 50 Hz	

j) Run-down

A certain pressure rise will occur due to pump motor run-down, if the pump is directly connected to a hydraulic cylinder via a pipe, such as e.g. in the typical connection pattern for clamping equipment (connection block B...) and if the power unit is switched off by a pressure switch as soon as a pre-selected pressure is achieved. The extent of this additional pressure rise depends on the pre-selected pressure, the volume of the connected consumers and the pump delivery rate. If such pressure rises are undesired, it will be necessary to reset the pressure limiting valve to match the shut-off point of the pressure switch. The result will be that all excess delivery of the pump during run-down will be conducted to the tank via the pressure limiting valve.

Procedure for matching is as follows:

1. Fully open the pressure limiting valve.
2. Adjusting the pressure switch on highest value (turning the adjustment screw clockwise up to the stop).
3. Start the pump (pressure gauge and all consumers connected) and turn up the pressure limiting valve until the pressure gauge shows the desired final operation pressure.
4. Turn back the pressure switch until the pump is switched off at the preset pressure (see sect. 3.)
5. Lock pressure switch and pressure limiting valve in position.

The effect of excessive run-down pressure may also be minimized by utilizing an accumulator or providing additional volume in the consumer line.

If the compact hydraulic power pack is running under full load, i.e. the preset pressure is close to the maximum permissible pressure as listed in sect. 2.1 and 2.2, then effectively no run-down will occur, as the pump will stop almost immediately after shut-off.

k) Selection of a connection block

A connection block is mandatory for the hydraulic connection of the hydraulic power pack

Type	Description	Pamphlet
A, AL, AM, AK, AS, AV, AP	For single circuit pumps with pressure limiting valve and the possibility for direct mounting of directional valve banks Optional: - pressure resistant filter or return filter - idle circulation valve - accumulator charging valve - Prop. pressure limiting valve	D 6905 A/1
AN, AL, NA, C30, SS, VV	For dual circuit pumps with pressure limiting valve and where directional valve banks can be directly mounted in some cases Optional: - accumulator charging valve - two stage valve - idle circulation valve	D 6905 A/1
AX	For single circuit pumps with pressure limiting valve (type approved) and the possibility for direct mounting of directional valve banks (for use at accumulator charged systems) Optional: - pressure resistant filter or return filter - idle circulation valve	D 6905 TÜV
B	For single circuit pumps for actuating single acting cylinders with pressure limiting valve and drain valve Optional: - throttle valve	D 6905 B
C	For single circuit pumps with ports P and R for direct piping	D 6905 C

l) Selection of the directional valve banks

The direct mounting of directional valves to the connection blocks type A enables creation of compact hydraulic units without additional piping.

Type	Description	Pamphlet
VB	Directional seated valves up to 700 bar	D 7302
BWN, BWH	Directional seated valves up to 450 bar	D 7470 B/1
BVZP	Directional seated valves up to 450 bar	D 7785 B
SWR, SWS	Directional spool valves up to 315 bar	D 7451, D 7951
BA	Valve bank for the combination of different directional valves with connection hole pattern NG 6 acc. to DIN 24 340-A6	D 7788
NBVP	Directional seated valves	D 7765 N
NSWP	Directional spool valves	D 7451 N
NSMD	Clamping modules (Directional spool valve with pressure reducing valve and feedback signal)	D 7787
NZP	Intermediate plate with connection hole pattern Ng 6 acc. to DIN 24 340-A6	D 7788 Z

5.2 Assembly and installation notes

Attention: The compact hydraulic power pack has to be installed and connected by a qualified technician, who is familiar with and works according to the generally accepted engineering standards and the latest legal regulations and standards.

The following guidelines and standards have to be taken into account:

- VDI 3027 "Initial operation and maintenance of hydraulic systems"
- DIN 24346 "Hydraulic systems"
- ISO 4413 "Hydraulic fluid power -- General rules relating to systems"
- D 5488/1 Pressure fluids - notes for selection
- B 5488 General operating manual for the assembly, initial operation and maintenance of hydraulic components and systems

a) Identification

see type plate or selection table in section 2

b) Installation and mounting

- Mounting hole pattern

 The hydraulic power pack incl. the solenoids of the directional valves can become hot during operation → Risk of injury!

Care has to be taken that fresh air can be drawn in and the warm air can escape.

Modifications of any kind (mechanical, welding or soldering works) must not be performed.

- Installed position only horizontally
- For dimensions, see sect.. 4.2
- For mounting hole pattern, see sect. 4.1
- Recommended fastening



- Mass (for the basic power pack without valve assembly and fluid)

Basic type	H	Z	HZ, HH, DHH, Z - H
HKL 3 HKLW 3.	19.7 kg	19.7 kg	20.5 kg
HKL 3.7 HKLW 3.7	21.9 kg	21.9 kg	22.7 kg
HKL 3.8 HKLW 3.8	27 kg	27 kg	27.5 kg
HKL 3.9 HKLW 3.9	21.5 kg	21.5 kg	22.3 kg
HKL 3.79 HKLW 3.79	23.7 kg	23.7 kg	24.5 kg
HKL 3.89 HKLW 3.89	28.8 kg	28.8 kg	29.3 kg

c) Electrical connection and setting of the protective motor switch

- For connection of the electric motor, see sect. 4.3
- For connection of the float and fluid level switch, see sect. 4.3

Note: The temperature switch will trigger at a fluid temperature of approx. 95°C.

Note: The signal has to be delayed sufficiently (time lag relay) if the lay-out of the system features an operation cycle where the pump is emptied below the min. level and replenished by the reflow from the consumer within one cycle.

- Adjustment of the protective motor switch
 - S1-operation (pressure $\leq p_1$)
The protective motor switch should be set for the corresponding current, required to achieve the adjusted pressure of the pressure limiting valve (see $I_M(p_V)$ calc.- curve sect. 3.3), however not higher than the nom. current I_N . This motor protection covers only a possible mechanical blockade of the motor.
 - S6-operation (pressure $\leq p_{max}$)
In most cases it is sufficient, to set the response current to approx. (0.85...0.9) of I_N . This makes sure that on one hand the bimetallic switch does not trigger too early during normal operation but on the other hand the oil temperature doesn't rise too high due to a prolonged response time after the pressure limiting valve is in action.
 - Test the setting of the motor protective switch during a test run. Temperature switches, float switches and pressure switches are further safety measures against malfunctions.

d) Notes to ensure EMC (Electromagnetic compatibility)

No impermissible spikes are emitted (EN 60034-1 sect. 19) when hydraulic power packs (inductive motor acc. to EN 60034-1 sect. 12.1.2.1) are connected to a system (e.g. power supply acc. to EN 60034-1 sect. 6). Tests regarding the conformity with EN 60034-1 sect. 12.1.2.1 and/or VDE 0530-1 are not required. Electro-magnetic fields may be generated during switching the motor ON/OFF. This effect can be minimized by means of a filter e.g. type 23140, 3 · 400V AC 4kW 50-60Hz (Co. Murr-Elektronik, D-71570 Oppenweiler)

e) Putting into operation

- Check, whether the compact hydraulic power pack is professionally connected.
 - Electrically: Power supply, controls
 - Hydraulically: Piping, hoses, cylinders, motors
 - Mechanically: Fastening at the machine, the frame, and the rack
- A protective motor switch should be employed to safeguard the electric motor.
For current setting, see sect. 5.2 c
- The pressure fluid to top-up the power pack should have passed the system filter or be fed via a filter unit always.
Only mineral oils conforming DIN 51524 part 1 to 3, type HL or HLP, with a viscosity of ISO VG 10 to 68 acc. to DIN 51519 are suited for use with this power pack. The water content must not exceed 0.1% (Danger of short-cut!)
Also suitable are biologically degradable pressure fluids type HEES (Synth. Ester) at service temperatures up to approx. +70°C.
Electrically hazardous: Any fluid types containing water must not be used (short-cut) i.e. fluids type HEPG and HETG are not suitable! The compact hydraulic power pack has to be topped-up to the max. marking of the fluid level gauge/dip-stick.

● Filling and usable volume	Tank size	Filling volume	Usable filling volume	
	Coding	$V_{filling}$	V_{usable} (coding H, Z)	V_{usable} (coding HZ, HH, DHH, Z - H)
	--	3.7 l	1.7 l	1.7 l
	7	4.1 l	2.1 l	1.7 l
	8	5.5 l	2.6 l	1.7 l
	9	11.2 l	8.2 l	8.2 l
	79	11.6 l	8.6 l	8.2 l
	89	13 l	9.1 l	8.2 l

- Initial operation and bleeding
The pump cylinders will be bled automatically if the pump is switched on and off several times while the connected directional valves are switched into a switching position where idle circulation is provided, if possible with your circuitry (see circuit diagram). Another way is to install a pipe fitting with a short piece of pipe and prolonged by a translucent tube. The other end of the tube should be put into the filler neck (breather removed), held firmly and sealed with a non-fluffing cloth. Now switch on the pump and let it run until no more bubbles are visible. Next after the pump cylinders are bled any air dragged into the system should be removed by opening the bleeder screws at the consumers (if provided) until no more bubble are detected or by operating all functions of the circuitry without load until all cylinders, motors, etc. move steadily and without any hesitation.
- Pressure limitation and pressure reducing valves
Do not a make any changes of the pressure setting without simultaneously checking the pressure with a pressure gauge!
- Directional valves
Solenoid valves apparent are to be connected to the controls according to the hydraulic wiring diagram and functional diagram.
- Accumulator charged systems
Accumulators have to be filled with appropriate equipment according to the pressure specifications of the hydraulic wiring diagram. The respective operating manuals have to be taken into account.

5.3 Servicing

The hydraulic power packs type MP and the valves being directly mounted onto the hydraulic power pack are almost maintenance free. Only the fluid level should be checked regularly depending on operation conditions.

The fluid should be exchanged every year as a general rule, but more frequently if tests show aging or contamination.

Attention:

Prior to maintenance and repair works the system has to be:

- depressurized (hydraulic side). This applies especially to systems with hydraulic accumulators
- cut-off or deenergized

Repairs and spare parts

Repairs (replacing service items) are possible by competent craftsmen. The motor can't be repaired or replaced by the customer. Therefore if the motor is defect, the complete pump should be returned to our facilities for an overhaul. There are spare parts lists available, pls. state your pump type acc. to the type plate either on the pump or on the cover plate.



HAWE Hydraulik SE
Streitfeldstr. 25
81673 Munich, Germany
Postfach 800804
81608 Munich, Germany
Tel. +49 (0)89 37 91 00-0
Fax +49 (0)89 37 91 00-12 69
e-mail: info@hawe.de
www.hawe.de